

# MD-1750 SERIES

CHASSIS DYNAMOMETER

## Maintenance & Service Manual

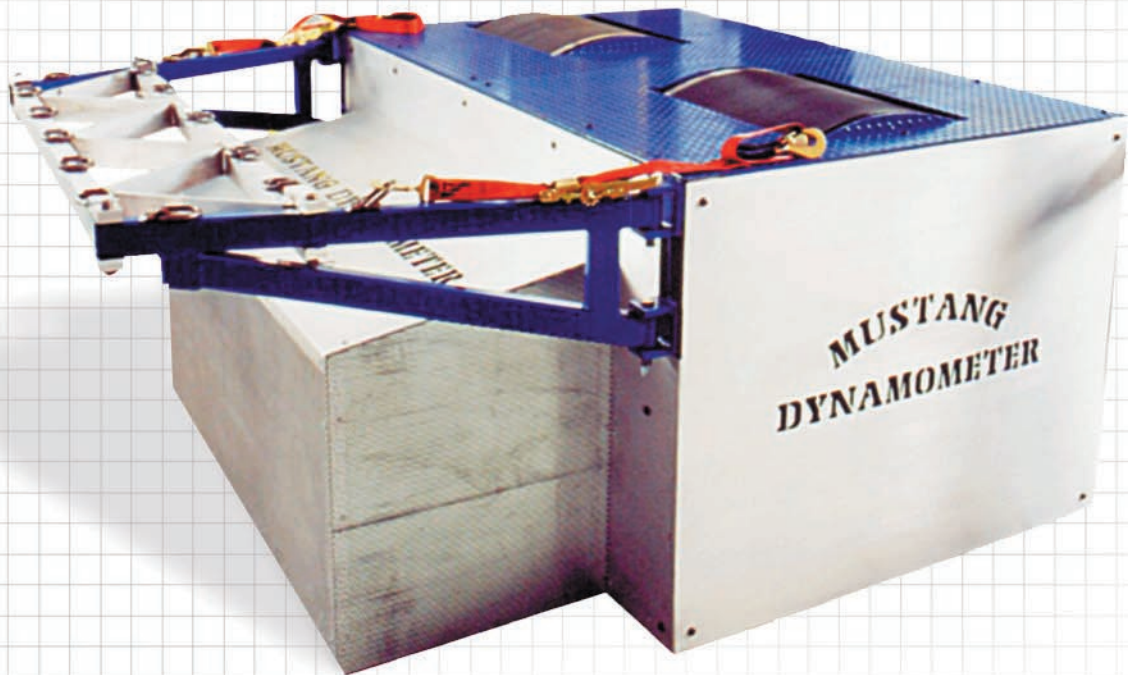

*Driving Excellence*  
*f u r t h e r*







Information in this document is subject to change without notice. No part of this document may be reproduced or transmitted in any form or by any means, electrical or mechanical, for any purpose, without the express written permission of Mustang Dynamometer.

Copyright © 2004  
Ganzcorp Investments, Inc. dba Mustang Dynamometer  
All rights reserved

### NOTICE

This manual has been designed and written to provide useful information about Mustang Dynamometer equipment and systems. Every effort has been made to make this manual as complete and accurate as possible, but no warranty or fitness is implied.

The information contained in this manual is provided on an "as is" basis. Neither the author of this manual nor the management and owners of Mustang Dynamometer shall have either liability or responsibility to any person or entity with respect to any loss or damages arising from the information contained in this manual.



2300 Pinnacle Parkway  
Twinsburg, Ohio 44087 USA  
Ph: (330) 963-5400  
Fax (330) 425-3310  
[www.mustangdyne.com](http://www.mustangdyne.com)



## WARNING

Do not operate or perform any maintenance on your equipment until you have carefully read this manual in its entirety making sure that you understand all of the material presented in each section.

## WARNING

Unsafe operating practices can lead to potentially dangerous situations when your machine is running.

Only properly trained and responsible personnel should attempt to operate this machine.

## WARNING

Removal and disassembly instructions in this manual have been reduced to a minimum for ease of readability.

Only experienced maintenance personnel should attempt to install and/or make repairs to this machine.

## WARNING

Keep limbs, hair, jewelry and clothing away from the moving rolls. When operating a vehicle on the machine, remain inside vehicle until the rolls have stopped. Cover the rolls when the equipment is not in use.



## ***WARRANTY LIMIT OF LIABILITY***

Mustang warrants that the product(s) that is the subject of this sale is free from defects in material. The duration of this warranty is one year from date of shipment on all Mustang-related components. Components not manufactured by Mustang will carry the original manufacturer's warranty, typically 90 days for all electronic-related components. All warranty claims must be processed through Mustang.

If a problem arises within the applicable warranty period, it is the responsibility of the purchaser to (a) promptly notify Mustang in writing (b) obtain a RMA Number from Mustang (c) return to Mustang the component(s) that are claimed to be defective (transportation charges must be prepaid by the purchaser). RMA Number must be clearly marked on outside of package(s).

Within a reasonable time after such notification, Mustang will correct any defect(s) in component(s). If Mustang is unable to repair the component after a reasonable number of attempts, or if Mustang determines at any time the repair is impracticable, Mustang will provide a replacement with like or similar component(s). The purchaser is responsible for all transportation expenses to and from Mustang and all labor expenses associated with removal and replacement of the component(s) as well as labor involved to repair component(s). Mustang will bear the expense of parts only. These remedies are the Purchaser's sole remedies for breach of warranty.

The expiration of the warranty period, use of the product for purposes other than those for which it is designed, other abuse or misuse, unauthorized attachments, modifications, or disassembly, or mishandling of the product during shipping, shall end all liability of Mustang.

In no case shall Mustang be liable for any special, incidental, or consequential damages based upon breach of warranty, breach of contract, negligence, strict tort, or any other legal theory. Such damages include but are not limited to, loss of profits, loss of savings or revenue, loss of use of the product or any associated equipment, cost of capital, cost of any substitute equipment, facilities or services, downtime, the claims of third parties including customers, and injury to property.

Unless modified in writing and signed by officers of both parties, this agreement is understood to be the complete and exclusive agreement between the parties, superseding all prior agreements, oral or written and all other communications between the parties relating to the subject matter of the agreement.

GANZCORP INVESTMENTS INC. dba MUSTANG DYNAMOMETER



## Table of Contents

### Section 1 - Introduction

1.1	What Is A Chassis Dynamometer	1-2
1.2	About This Manual	1-3
1.3	Important Message Boxes	1-4
1.4	Before You Start	1-5
1.5	If You Need Help	1-5

### Section 2 - The System

2.1	Introduction	2-2
2.2	Major System Components	2-2
2.2.1	Dynamometer	2-3
2.2.2	Control & Monitoring System	2-4
2.2.3	Software System	2-5
2.3	Principles Of Operation	2-6

#### List of Figures

Fig. 2.1	Major Components of the Dynamometer Sub-system	2-3
Fig. 2.2	Major Components of the Control & Monitoring Sub-system (Part 1 of 2)	2-4
Fig. 2.3	Major Components of the Control & Monitoring Sub-system (Part 2 of 2)	2-5

### Section 3 - Safety First

3.1	Introduction	3-2
3.2	General Safety Issues	3-3
3.3	Operational Safety Issues	3-4
3.4	Maintenance Safety Issues	3-5

### Section 4 - Installation

4.0	Introduction	4-2
4.1	Inspection	4-2
4.2	Tools & Equipment Needed For Installation	4-2
4.3	Shop Layout & Requirements	4-3
4.3.1	Pit Excavation (below-ground installation only)	4-3
4.3.2	Electrical	4-3
4.3.3	Pneumatic (Air)	4-3
4.3.4	Ventilation	4-3
4.3.5	Floor Anchors	4-4
4.3.6	Clearance	4-4
4.4	Above Ground Installation	4-4
4.5	Below Ground Installation	4-6
4.6	Control Installation	4-8
4.7	Pre-operational Inspection	4-12

#### LIST OF FIGURES

Fig. 4.1	Control System	4-8
Fig. 4.2	Lift Solenoid	4-9
Fig. 4.3	PAU Wiring	4-9
Fig. 4.4	Computer Connections	4-10
Fig. 4.5	Drive Control Box	4-11

### Section 5 - Operational Checkout

5.1	Introduction	5-2
5.2	Initial Start	5-2

## Section 6 - Preventative Maintenance

6.1 Introduction	6-3
6.2 General Information	6-3
6.2.1 Pillow Block Bearings	6-3
(A.) Expansion/Non-Expansion Bearings	6-3
(B.) Locking Bearing to Shaft	6-4
6.2.2 Gear Tooth Couplings	6-4
6.3 Preventative Maintenance Time Table	6-6
6.4 Lubrication	6-7
6.4.1 General Information	6-7
6.4.2 Pillow Block Bearings	6-8
6.4.3 Couplings	6-9
6.4.4 Power Absorber	6-11
6.5 Inspection & Adjustments	6-12
6.5.1 Check Torque of Bearing Set & Hold Down Screws	6-12
6.5.2 Check Torque of Coupling Set Screw	6-12
6.5.3 Check Condition of Coupling Key	6-12
6.5.4 Check for Roll Lock Brake Pad Wear	6-12
6.5.5 Check Condition & Tension of Belt	6-13
(A) Condition Check	6-13
(B) Tension Check	6-13
6.5.6 Power Absorbing Unit Checks	6-13
(A) Check Bearing End Play	6-14
(B) Check Rotor Air Gaps	6-14
6.6 Cleaning & Corrosion Prevention	6- 15
6.6.1 Cleaning Your Machine	6-15
6.6.2 Cleaning The Pit (If Applicable)	6-15
6.6.3 Corrosion Prevention	6-15

### LIST OF FIGURES

Fig. 6.1 Hub & Sleeve Gear Tooth Coupling	6-5
Fig. 6.2 Hub & Flange Gear Tooth Coupling	6-5
Fig. 6.3 Pillow Block Bearing Setscrews & Lube Point	6-8
Fig. 6.4 Coupling Setscrews, Lube & Relief Points	6-10
Fig. 6.5 PAU Lube & Relief Points	6-11
Fig. 6.6 PAU Checking Nomenclature	6-14

### LIST OF TABLES

Table 6.1 Preventative Maintenance Time Table	6-6
Table 6.2 Suggested Lubrication Period (in Weeks)	6-9

## Section 7 - Troubleshooting

7.1 Introduction	7-2
7.2 Troubleshooting Guide	7-3

## Section 8 - Appendix

Appendix A - Torque Specifications	
Appendix B - Recommended Fluids	
Appendix C - Anchor Pod Installation - New Floors	

## Specification



## CONTENTS

1.1	What Is A Chassis Dynamometer .....	1-2
1.2	About This Manual .....	1-3
1.3	Important Message Boxes .....	1-4
1.4	Before You Start .....	1-5
1.5	If You Need Help .....	1-5







## 1.1 What is a Chassis Dynamometer

Today and in the future, automobiles and trucks will be required to meet increasingly stringent emissions and safety standards. In many cases, dynamic testing - either on-highway or with a chassis dynamometer - is the only way to adequately measure vehicle performance or emissions.

A Mustang Chassis Dynamometer (sometimes referred to as a "Dyne" or "Dyno") is a rugged piece of equipment which is used to apply a load to a test vehicle. The Mustang Chassis Dyne is an integrated assembly of mechanical, electro-mechanical, and electrical/electronic sub-systems which function together to provide you with the ability to simulate actual road loads while the vehicle being tested remains in the safe and controlled confines of a test center. In addition to the vehicle performance information provided by the Dynamometer System during a test, this capability will also enable you to connect test instruments and diagnostic equipment to the test vehicle's engine to monitor specific engine performance characteristics.

As the torque from the test vehicle's drive wheels causes the rolls of the Dyne to rotate, Mustang's air-cooled electrical eddy current Power Absorbing Unit (PAU) opposes this force by converting the vehicle's kinetic energy into heat. A microcomputer-based control unit, using closed-loop feedback control, regulates the amount of power that is absorbed by the PAU and, as a result, the amount of load that is imposed on the test vehicle.

The Chassis Dynamometer has emerged as a major asset in the areas of Emissions Testing, Fault Diagnosis, Performance Engineering, and Test Engineering throughout the world. Chassis Dynamometers can be used to perform a wide variety of tests on vehicles; some examples of these tests deal with ...

- Vehicle Heating & Cooling Systems
- Engine Performance and Evaluation
- Drive Train Component Evaluation
- Transmission Components
- Tire Testing
- Track Lap Simulation
- Road Grade Simulation
- Trailer Towing Simulation
- Fuel Efficiency
- Auxiliary Components
- Failure Analysis



## 1.2 About This Manual

This manual provides you with the information you will need to know when you want to install and perform routine maintenance as well as more complex service on your MD-1750 Chassis Dynamometer. The following sections are included in this manual:

### Section 1 - Introduction

This is the section you are currently reading.

### Section 2 - The System

This section presents a description of the MD-1750 Chassis Dynamometer System to familiarize you with its major components. In addition, the principles of dynamometer operation are discussed.

### Section 3 - Safety First

A number of very important safety tips are presented in this section. **BE SURE TO STUDY THIS SECTION CAREFULLY!**

### Section 4 - Installation

A step-by-step procedure is given in this section to help ensure that your Dyne is installed properly.

### Section 5 - Operational Checkout

A sequence of operational checks is provided in this section to verify that your system is operating properly.

### Section 6 - Preventative Maintenance

General maintenance and lubrication instructions are presented in this section.

### Section 7 - Troubleshooting

Some basic troubleshooting hints are contained in this section.

### Section 8 - Appendices

The appendices contain reference information that you can easily access when you need it.

### Specifications

General equipment specifications.

### 1.3 Important Message Boxes

When you read this manual and operate and maintain your Mustang Dynamometer System ...

**Be sure to observe all DANGER, WARNING, and CAUTION advisories!**

These advisories point out potentially hazardous procedures and conditions. As can be seen below, all three types of advisories are enclosed in a box to call attention to them.

	<b>DANGER</b>
	This is an example of a DANGER message. A DANGER message alerts a person that severe bodily injury or loss of life could occur if procedures are not followed.

	<b>DANGER</b>
	This is an example of an electrical DANGER message. An electrical DANGER message alerts a person that, as a result of electrical shock, severe bodily injury or loss of life could occur if procedures are not followed.

	<b>WARNING</b>
	This is an example of a WARNING message. A WARNING message alerts a person to potential bodily injury if procedures are not followed.

	<b>CAUTION</b>
	This is an example of a CAUTION message. A CAUTION message alerts a person that if procedures are not followed, damage to, or destruction of the equipment could result.

	<b>NOTE</b>
	This is an example of a NOTE box. A NOTE box is generally used to bring to your attention information that should be of particular benefit, information that pertains to a special situation, etc.



## 1.4 Before You Start

Before attempting to operate your Dynamometer for normal usage, it is very important that...

- Your Dynamometer has been properly installed.
- Your Dynamometer has been properly maintained.
- Your Dynamometer has been properly calibrated. Please refer to the MD-7000 Software Manual - Chapter 6 Calibration.
- No unsafe conditions exist with your Dynamometer or your work site.
- All personnel who will be performing maintenance and service on your Dynamometer have read this manual in its entirety and understand all of the information presented.

## 1.5 If You Need Help

Much effort has been extended to make this manual easy to work with as well as complete and accurate. However, if there is something that you do not understand or something that you have a question about, please feel free to contact a Mustang representative at ...



### **MUSTANG DYNAMOMETER**

2300 Pinnacle Parkway  
Twinsburg, Ohio 44087 USA

Ph: (330) 963-5400

Fax: (330) 425-3310

[service@mustangdyne.com](mailto:service@mustangdyne.com)

## CONTENTS

2.1	Introduction .....	2-2
2.2	Major System Components .....	2-2
2.2.1	Dynamometer .....	2-3
2.2.2	Control & Monitoring System .....	2-4
2.2.3	Software System .....	2-5
2.3	Principles Of Operation .....	2-6

## LIST OF FIGURES

Fig. 2.1	Major Components of the Dynamometer Sub-system .....	2-3
Fig. 2.2	Major Components of the Control & Monitoring Sub-system (Part 1 of 2) .....	2-4
Fig. 2.3	Major Components of the Control & Monitoring Sub-system (Part 2 of 2) .....	2-5



## 2.1 Introduction

This section of the manual provides general information that will help you to develop a comprehensive understanding of your MD-1750 Dynamometer System. The following topics are covered in this section:

- Major System Components
- Principles of Operation

When learning to operate and/or maintain your new Dynamometer we strongly suggest that you take a few moments to familiarize yourself with the information presented in this section of the manual. Doing so will greatly help you to understand the information that is presented in other sections of this manual.

## 2.2 Major System Components

The major components of a MD-1750 Dynamometer System can be grouped into the following categories which are discussed below:

- Dynamometer
- Control & Monitoring System
- Software System

## 2.2.1 Dynamometer

The Dynamometer sub-system is defined here as being comprised of primarily those system components that are "mechanical" or "structural" in nature. These components are illustrated and discussed below (see Fig. 2.1).

**FIG. 2.1**  
MAJOR COMPONENTS  
OF THE DYNAMOMETER  
SUB-SYSTEM

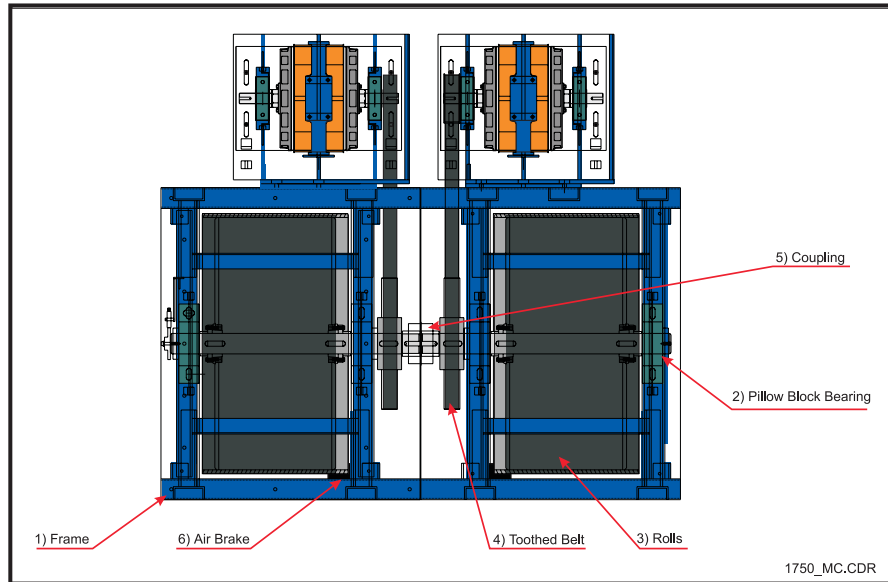

**NOTE:** Your configuration may have differences from the figure shown. For example, you may have a single PAU, etc.

### KEY (Fig. 2.1)

<b>1... Frame</b>	Double welded heavy structural steel frame.
<b>2... Pillow Block Bearings</b>	Ball bearings are mounted in a gray iron pillow block housing for exceptional strength. Bearings can float to minimize misalignment of shafts.
<b>3... Rolls</b>	The dyne is equipped with a 50" diameter soll set. All rolls are dynamically balanced for speeds up to 225 MPH. The surfaces of the rolls are knurled to provide maximum traction and good tracking.
<b>4... Toothed Belt</b>	Rugged toothed drive belt used to couple rolls to PAUs.
<b>5... Coupling</b>	High power couplings are used to accurately transmit speed and power to instrumentation.
<b>6... Brake System</b>	The pneumatic braking system locks the rolls to allow for easy vehicle mounting and strap-down. The air brake should not be used to stop the dynamometer as this will cause excessive wear to the brake pad. Use the power absorbers to bring the dynamometer to a stop before activating the air brake.

## 2.2.2 Control & Monitoring System

The Control & Monitoring Sub-system is defined here as being comprised of those electrical, electro-mechanical, and electronic system components that are primarily used to control the operation of the system and to monitor the behavior of the vehicle during a test. Only those Control & Monitoring Sub-system components that are mounted on the dynamometer are considered in this section; these components are illustrated and discussed below (see Fig. 2.2).

**FIG. 2.2**  
MAJOR COMPONENTS  
OF THE CONTROL &  
MONITORING SUB-SYS-  
TEM (part 1 of 2)

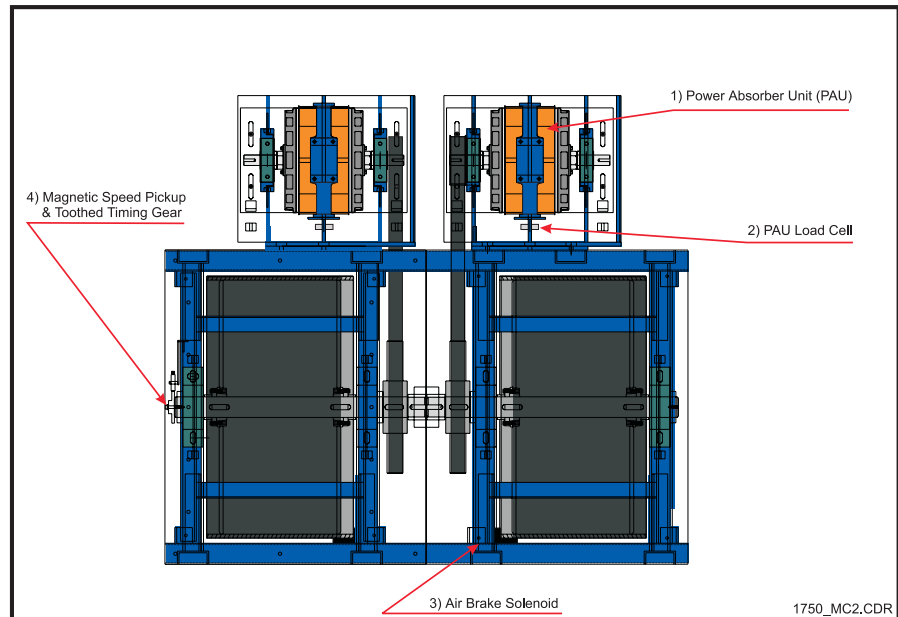

**NOTE:** Your configuration may have differences from the figure shown. For example, you may have a single PAU, etc.

### KEY (Fig. 2.2)

- 1... Power Absorber Unit (PAU)** Eddy current Power Absorbing Units (PAUs) provide infinitely variable loading without the use of water or hydraulics. The PAU can operate while rotating in either direction. Its rugged construction enables it to be operated under extremely demanding conditions. The PAU is wired for 96 VDC operation.
- 2... PAU Load Cell** The strain gauge load cell, excited with 10 VDC, produces a DC output signal as it is either compressed or expanded. The rated accuracy of the Load Cell is  $\pm 0.1\%$ .
- 3... Air Brake Solenoid** This valve controls the flow of pressurized air (maximum valve of 80 PSI) to the brake air bags enabling them to quickly inflate and deflate.
- 4... Mag Pickup** One revolution of the drive line will cause 60 pulses to be generated. By measuring the time between pulses generated, the speed of rotation can be calculated.



**FIG. 2.3**  
MAJOR COMPONENTS  
OF THE CONTROL &  
MONITORING SUB-SYS-  
TEM (part 2 of 2)

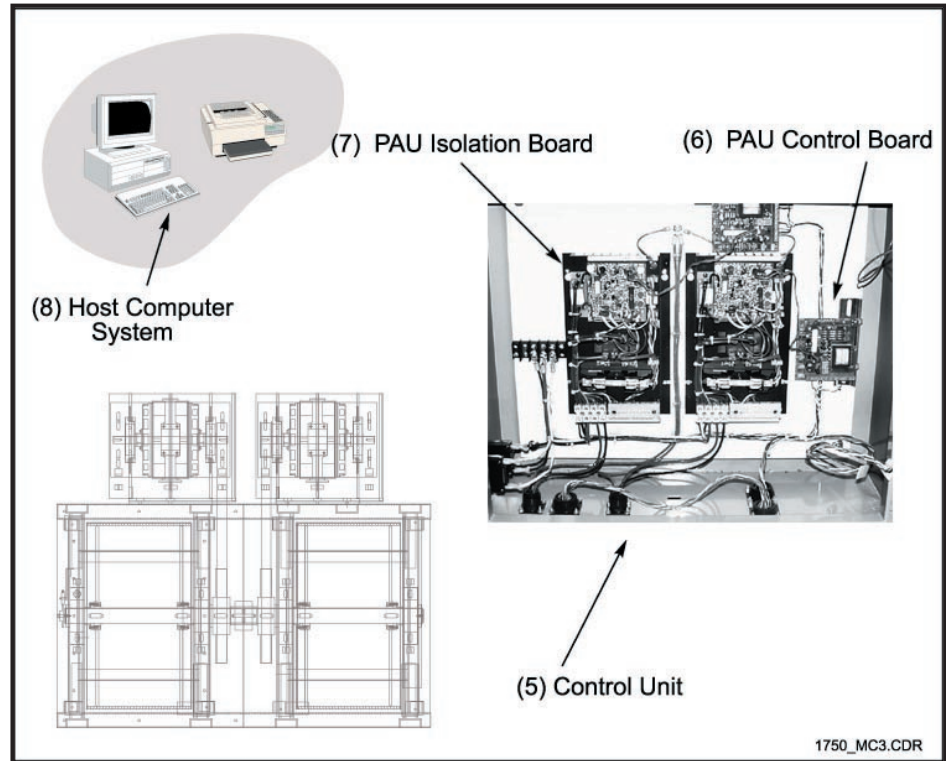

**NOTE:** Your configuration may have differences from the figure shown. For example, SE model is slightly different than a DE model controller, etc.

**KEY (Fig. 2.3)**

- |                                 |  |
|---------------------------------|--|
| <b>5... Control Unit</b>        | This unit houses circuitry that converts the computer commanded inputs into outputs that are furnished to the PAU's.                   |
| <b>6... PAU Control Board</b>   | The PAU Control Board uses a 0-5 VDC input signal from the Isolation Module to produce a 0-96 VDC output that is furnished to the PAU. |
| <b>7... PAU Isolation Board</b> | The PAU Isolation Board optically isolates the control signals from the PAU Control Board.   |
| <b>8... Host Computer</b>       | The host computer system houses the analog/digital conversion boards along with the MD7000 proprietary software package.               |

**2.2.3 Software System**

The MD-7000 Dynamometer Control System is provided by Mustang Dynamometer and is run on the System Host Computer. For more information pertaining to the software, please consult the operation manual.



## 2.3 Principles of Operation

A Mustang Chassis Dynamometer will give you the ability to simulate actual road loads while the vehicle is stationary. This enables you to perform tests on a vehicle while test diagnostic instruments are connected to the vehicle's engine and exhaust system.

The Dynamometer consists primarily of drive roll set, a power absorbing unit(s) (PAU), a load cell(s), and a speed encoder.

During operation of the Dyne, the vehicle's drive wheels on top of the drive rolls. The vehicle's torque is transmitted through the drive rolls to the eddy-current Power Absorbing Unit (PAU). The PAU is belted directly in the dyne's drive line. It is prevented from "freely" rotating by the installation of a load cell. The "load" is measured by the load cell and is transmitted to the control system via an electrical signal. The PAU absorbs this load by energizing stationary electric field coils with a direct current. These coils establish magnetic fields through which the iron rotors of the PAU are rotated. This rotation generates eddy-currents in the rotors which produce a force that is counter to the direction of the rotary motion. The power absorbed by the PAU is dependent upon the amount of DC power applied to the field coils and the RPM of the spinning rotors. The speed of rotation of the rotors is measured by a magnetic device called a mag pickup and is transmitted to the control system.

When both torque (from the load cell signal) and speed (from the mag pickup signal) are known, horsepower can easily be determined.



## CONTENTS

<b>3.1</b>	<b>Introduction .....</b>	<b>3-2</b>
<b>3.2</b>	<b>General Safety Issues .....</b>	<b>3-3</b>
<b>3.3</b>	<b>Operational Safety Issues .....</b>	<b>3-4</b>
<b>3.4</b>	<b>Maintenance Safety Issues .....</b>	<b>3-5</b>

## 3.1 Introduction

<b>DANGER</b>	
	<p style="text-align: center;"><b>Attention!</b></p> <p>Dynamometer operation is potentially dangerous. For your own safety, read and understand the following warnings before conducting any tests. If you cannot read English, or have difficulty understanding these warnings, please ask a supervisor or co-worker to explain them to you.</p>

<b>DANGER</b>	
	<p>This equipment contains voltages which may be hazardous if contacted. Avoid contacting terminals, binding posts, and other exposed connections.</p>

Throughout this manual you will encounter **DANGER**, **WARNING**, and **CAUTION** messages. These messages are intended to alert you to situations that are potentially dangerous to you or damaging to your machine. Please pay attention to these advisories and follow the directions given in them.

The safety messages presented below are categorized as follows:

- General Safety Issues
- Operational Safety Issues
- Maintenance Safety Issues

The **General Safety Issues** apply whenever you are working with the dyne for any reason.

The **Operational Safety Issues** alert you to hazards that may arise during the operation of the dynamometer whether it is being operated for vehicle testing or during an operational checkout.

The **Maintenance Safety Issues** alert you to hazards that may arise when you are performing maintenance and service on your dynamometer system.

Please be sure to read and follow the directives in all of the safety messages given in this section.



## 3.2 General Safety Issues

**Be Knowledgeable ...** Do not attempt to operate, maintain or service your Chassis Dynamometer System until you have familiarized yourself with the equipment by reading the instructions in this manual.

**Prepare Correctly ...** To avoid possible injury to personnel or damage to equipment do not apply power to your Dynamometer System until the following procedures have been satisfactorily completed:

- Installation (Section 4)
- Operational Checkout (Section 5)

**Act Responsibly ...** Exercise caution and discretion when operating or performing maintenance on your dyne. Always observe typical, common sense test area precautions.

**Beware of Projectiles ...** Tires that are rotating at high rates of speed can throw off stones and other projectiles. Wear approved safety glasses when in the vicinity of the vehicle being tested.

**Protect Your Ears ...** Dynamometer noise can damage your hearing. Always wear approved ear protection when working near the dynamometer.

**Beware of Being Grabbed ...** Keep limbs, hair, jewelry, and clothing away from the moving dynamometer rolls, belt, couplings, etc.

**Cover Rolls ...** The rolls can move freely whenever the roll brake is not applied. Never walk on the rolls. Cover the rolls when the dynamometer is not in use.

**Pay Attention ...** Maintain acute awareness when the dynamometer rolls are in motion.



## 3.3 Operational Safety Issues

**Vent Engine Exhaust ...** Provide adequate room ventilation. High concentrations of engine exhaust can be deadly. Do not operate your Dynamometer without proper ventilation. The shop ventilation system should exchange 300 to 500 cubic feet of air per minute (500 cfm preferred).

**Monitor Carbon Monoxide ...** Make sure you have installed a carbon monoxide monitor in the dynamometer bay.

**Guarding ...** Provide floor markings and protective guard railings for customer/operator protection. **NEVER** operate your Dyne with any of its cover panels removed unless specifically directed to do so elsewhere in this manual.

**Refresh Your Knowledge ...** Regularly review the operating procedures presented in this manual.

**Keep Clear of Rolls ...** Stay away from the rolls when in operation.

**Protect Eyes and Ears ...** Make sure that you wear proper eye and ear protection when operating the dyne.

**Check Tires ...** Before driving the test vehicle onto the dyne, be sure to check the vehicle's tires for proper inflation. Inspect the tires for any signs of damage and remove any large embedded objects from the tread.

**Restrain Vehicle Movement ...** During dynamometer operation it is common for the test vehicle to move laterally on the rolls. Also, unrestrained vehicles can launch off the dyne, causing death or serious injury.

To prevent personal injury and/or damage to the test vehicle, it is imperative that, prior to testing the vehicle, you secure the test vehicle in all directions (front, rear, and sides) with approved safety restraints that are bound to properly installed floor anchor pods.

**Wheel Chocks ...** Use wheel chocks for the vehicle that is under test. Install one inch in front of non-driven wheels of test vehicle.

**Proper Clearance ...** Always ensure that there is a clearance of at least four (4) feet to the front, rear, and sides of the dynamometer.

**Stay Seated ...** The vehicle operator **MUST** remain in the driver's seat at all times during a drive-cycle test. **DO NOT** attempt to get in or out of the vehicle while the dynamometer rolls are moving.

**If in Doubt, STOP! ...** Stop the equipment immediately if you have any doubt about the safe operating condition of the dynamometer and/or the correctness of any procedure that you are performing.



## 3.4 Maintenance Safety Issues

**Electrical Shock Hazard ...** Turn off electrical service to the system before performing any maintenance activity. Turn off the main breaker in your breaker box before working on anything related to the PAU.

**No Jewelry ...** Before performing any electrical or mechanical trouble-shooting, repair, etc. on the dyne, it is highly advisable to remove any jewelry that you may be wearing..

**Dyne Cover Panels ...** Use extreme caution around drive mechanisms and moving parts when operating the dyne with any of its cover panels removed from the chassis assembly.

**Avoid Straining Yourself ...** Be careful when lifting dyne cover panels - they are very heavy. Be very careful when replacing belts, couplings, or bearings - the rolls are very heavy and can be difficult to handle.

**Air Pressure ...** Make sure that there is no air pressure in the lines whenever you are working on the lift plates, roll brakes or air bags.

**Watch Your Hands ...** Never put your hand between the roll brakes and roll when there is air hooked up to the system.

**NEVER, NEVER, NEVER! ...** Never pull on the drive belt in order to spin the rolls.

**Check Tightness ...** Make sure that all bolts on the Dyne are tight and all couplings are properly secured.

### CONTENTS

<b>4.0</b>	<b>Introduction</b> .....	<b>4-2</b>
<b>4.1</b>	<b>Inspection</b> .....	<b>4-2</b>
<b>4.2</b>	<b>Tools &amp; Equipment Needed For Installation</b> .....	<b>4-2</b>
<b>4.3</b>	<b>Shop Layout &amp; Requirements</b> .....	<b>4-3</b>
<b>4.3.1</b>	<b>Pit Excavation (below-ground installation only)</b> .....	<b>4-3</b>
<b>4.3.2</b>	<b>Electrical</b> .....	<b>4-3</b>
<b>4.3.3</b>	<b>Pneumatic (Air)</b> .....	<b>4-3</b>
<b>4.3.4</b>	<b>Ventilation</b> .....	<b>4-3</b>
<b>4.3.5</b>	<b>Floor Anchors</b> .....	<b>4-4</b>
<b>4.3.6</b>	<b>Clearance</b> .....	<b>4-4</b>
<b>4.4</b>	<b>Above Ground Installation</b> .....	<b>4-4</b>
<b>4.5</b>	<b>Below Ground Installation</b> .....	<b>4-6</b>
<b>4.6</b>	<b>Control Installation</b> .....	<b>4-8</b>
<b>4.7</b>	<b>Pre-operational Inspection</b> .....	<b>4-12</b>

### LIST OF FIGURES

<b>Fig. 4.1</b>	<b>Control System</b> .....	<b>4-8</b>
<b>Fig. 4.2</b>	<b>Lift Solenoid</b> .....	<b>4-9</b>
<b>Fig. 4.3</b>	<b>PAU Wiring</b> .....	<b>4-9</b>
<b>Fig. 4.4</b>	<b>Computer Connections</b> .....	<b>4-10</b>
<b>Fig. 4.5</b>	<b>Drive Control Box</b> .....	<b>4-11</b>



## 4.0 Introduction

This section of the manual provides detailed instructions that you should follow when installing your new Chassis Dynamometer.

These instructions cover the installation of most Mustang models (i.e., standard & heavy-duty, uni- and bi-directional). Both in-ground and above-ground installations are covered as well as various methods of securing the dyne to the floor (ex. weld plates, stud anchors, anchor bolts).

## 4.1 Inspection

After unloading the dynamometer from the delivery truck and prior to the departure of the truck driver a visual inspection must be made of the dynamometer. If there is any apparent damage to the shipping crates it must be noted on the bill of lading prior to accepting delivery of the dynamometer. After uncrating the equipment check the contents of the crates with the enclosed packing list. The following is a list of items that should have been received. Notify MUSTANG DYNAMOMETER immediately if you find any shortages or damage with this shipment.

1. Dynamometer
2. Dyne control box
3. Control box to dyne cable
4. Computer to control box cable
5. Load cell
6. Speed encoder (mounted on dynamometer)
7. Chain anchors (4)
8. Chains and binders (2 sets)
9. Remote hand controller
10. Anchor studs (7)
11. Air line
12. Manual
13. Software backup disk(s)

## 4.2 Tools & Equipment Needed for Installation

1. Shim stock (can be purchased separately from MD)
2. 1/2" Eyebolts (4), to lift dynamometer  
(can be purchased separately from MD)
3. Chains with hooks (2)
4. 5/8" Masonry drill bit
5. Hammer drill
6. Forklift, minimum 6 ton capacity
7. Standard hand tools

## 4.3 Shop Layout & Requirements

This section includes minimum requirements necessary to install the Dynamometer and to ensure safe operation. After determining which method of installation is best for you it is necessary to adhere to the following conditions.

### 4.3.1 Pit Excavation (Below-Ground Installation Only)

A below ground installation requires a floor opening of very specific dimensions. A drawing has been provided with your dynamometer depicting proper pit dimensions. It is recommended that you contract the services of a licensed contractor to perform the excavating of the dynamometer pit.

	WARNING
<p>The installer of the dynamometer accepts full responsibility for adhering to local, state and federal construction codes. The factory will not be held liable for damage or injury caused by improper installation.</p>	

### 4.3.2 Electrical

A 110 volt AC, single phase, 15 amp circuit is required for the Host Computer System.

Dynamometer Electrical Service	
MD-100	230 VAC single phase, 60 Hz, 30 Amps
MD-250	230 VAC single phase, 60 Hz, 40 Amps
MD-750	230 VAC three phase, 60 Hz, 40 Amps
MD-1000	230 VAC three phase, 60 Hz, 40 Amps
MD-1750 single PAU	230 VAC, single phase, 60 Hz, 40 Amps
MD-1750 dual PAU	230 VAC, three phase, 60 Hz, 40 Amps

Your local electrical codes will determine how these circuits should be wired.

### 4.3.3 Pneumatic (Air)

The Dynamometer requires an air supply line to operate the lift and brake systems. The airline should supply at least 80 psi but not more than 120 psi. An air dryer and regulator should be installed in the main supply line with the regulator set for 80 psi.

### 4.3.4 Ventilation

Your shop should be equipped with an effective ventilation system to direct tailpipe emissions to the outside air. Exhaust vents should be able to connect to all type of vehicles (front-wheel drive, rear wheel drive, dual exhaust, etc.)

### 4.3.5 FLOOR ANCHORS

It is common for vehicles to move laterally on the rollers during dynamometer operation. To prevent personal injury and damage to the vehicle it is imperative that the vehicle be secured with chains or straps. The dynamometer is supplied with 4 floor anchors that must be permanently installed as illustrated in the Appendix.

### 4.3.6 CLEARANCE

It is important to have enough room around the dynamometer to allow equipment to be moved around the service bay area. At least 18 feet clearance is needed in front of the dynamometer so that the vehicle under test has enough room to pull in the service bay.

There are two ways to install a Dynamometer, above ground or below ground. The following section describes both methods.

## 4.4 Above-Ground Installation

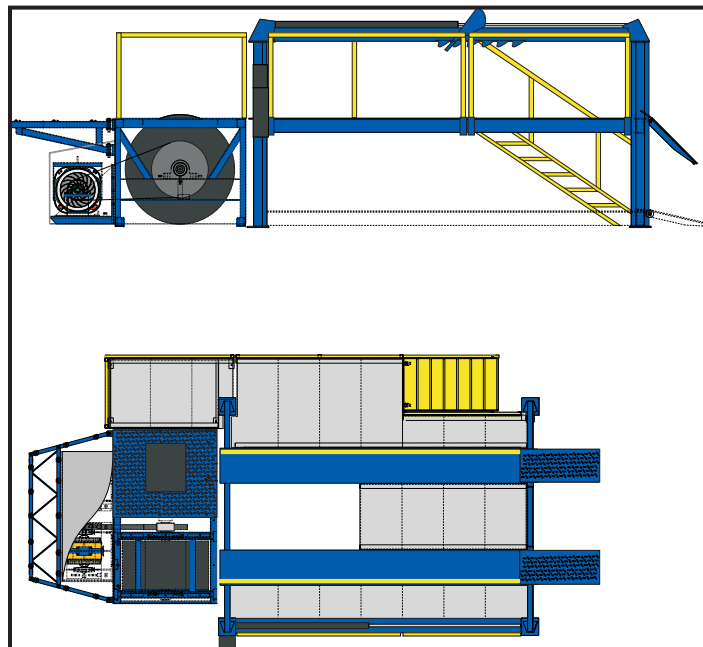

**NOTE:** Your configuration may have differences from the figure shown.

If using this type of installation the dyne and lift will be anchored to the shop floor using "thunder studs". Since the top surface of the dyne will be off of the ground, an optional 4-Post Lift is needed to drive the front or the rear of the car to the rolls.



### **Advantages**

- Less expensive type of installation
- An existing shop requires little renovation
- Easy to move dynamometer
- 4-post lift can be used for other purposes when dyne is not in use.
- Allows access to all points of the vehicle while on dyne

### **Disadvantages**

- Dynamometer and lift take up floor space
- Not recommended for high speed testing

## **4.4.1 Above-Ground Installation Procedure (Dynamometer Only)**

1. Remove rear PAU cover and side panels from the dynamometer.
2. Lift the dynamometer with a forklift and locate it in an appropriate location, keep in mind the clearance requirements discussed in the previous section.
3. Remove the lift plate opposite the retarder.
4. In the 7 anchor locations, drill 5/8" diameter holes 6" deep into the concrete. Ensure the holes are clear of dust and debris.
5. With the dynamometer in position, level the dynamometer using steel shim stock. If the dynamometer needs shims, place them underneath the dynamometer frame near the 7 anchor locations.
6. With the nut of the "Thunderstud" flush with the top of the stud, tap the "Thunderstuds" into the holes until the washer is flush with the dynamometer frame.
7. Expand the anchors by tightening the nut.
8. Re-install lift plates, torque bolts to 35 ft-lbs.

**Please refer to 4-post lift operators manual for Lift installation procedures.**

## 4.5 Below-Ground Installation

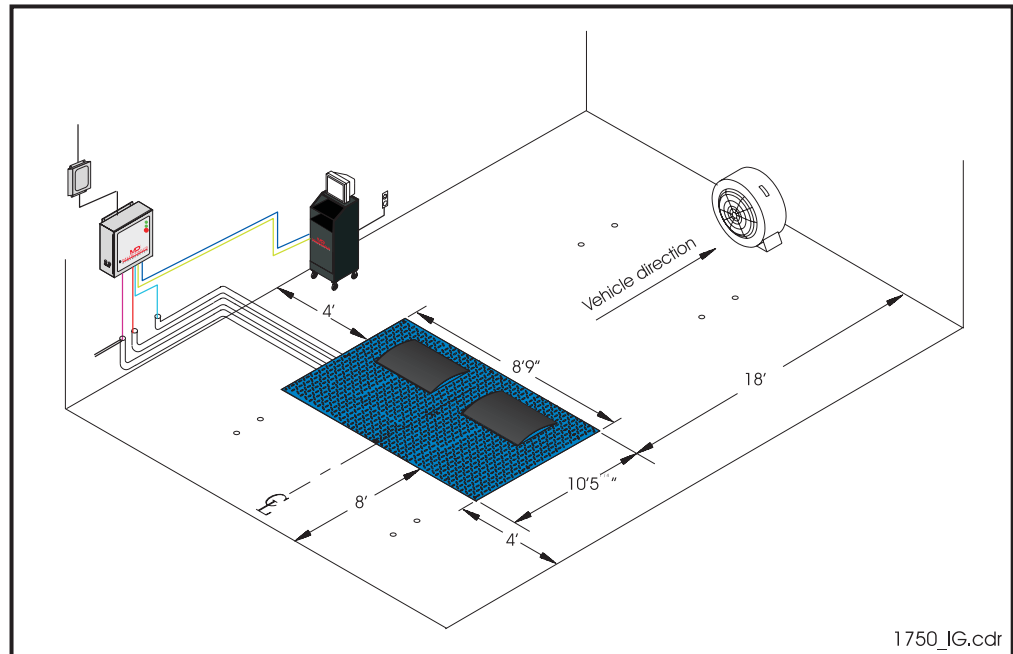

**NOTE:** Your configuration may have differences from the figure shown.

The Dynamometer is lowered into a pit, allowing the rollers to be flush with the floor surface.

### Advantages

- The bulk of the dynamometer is below ground
- Vehicles are level with the ground
- Easy to drive vehicle on & off of dynamometer

### Disadvantages

- More expensive installation costs
- Requires renovation to existing shop
- Dynamometer cannot be easily moved



### 4.5.1 Below-Ground Installation Procedure

1. Check dynamometer pit and verify dimensions. Also, make sure the conduits are in the proper locations.
2. Clear the pit of all debris.
3. Remove cover plates from the dynamometer. Screw the 4 eyebolts into the holes along the main frame. Secure the chain to the eyebolts.
4. Lift the dynamometer evenly with the chain and lower it into the pit. There should be approximately 1/2" clearance between the frame and all walls of the pit.
5. Remove the lift plate opposite the retarder.
6. In the 7 anchor locations, drill 5/8" diameter holes 6" deep into the concrete. Ensure the holes are clear of dust and debris.
7. With the dynamometer in position, level the dynamometer using steel shim stock. If the dynamometer needs shims, place them underneath the dynamometer frame near the 7 anchor locations.
8. With the nut of the "Thunderstud" flush with the top of the stud, tap the "Thunderstuds" into the holes until the washer is flush with the dynamometer frame.
9. Expand the anchors by tightening the nut.
10. Re-install the lift plates, torque bolts to 35 ft-lbs.

## 4.6 Controls Installation

The dynamometer control system consists of a drive control box, computer system, remote control, and associated cables ( refer to Fig. 4.1 ). If the dynamometer is not to be installed in a pit, wire covering should be used to protect cabling and air lines.

**FIG. 4.1**  
CONTROL SYSTEM

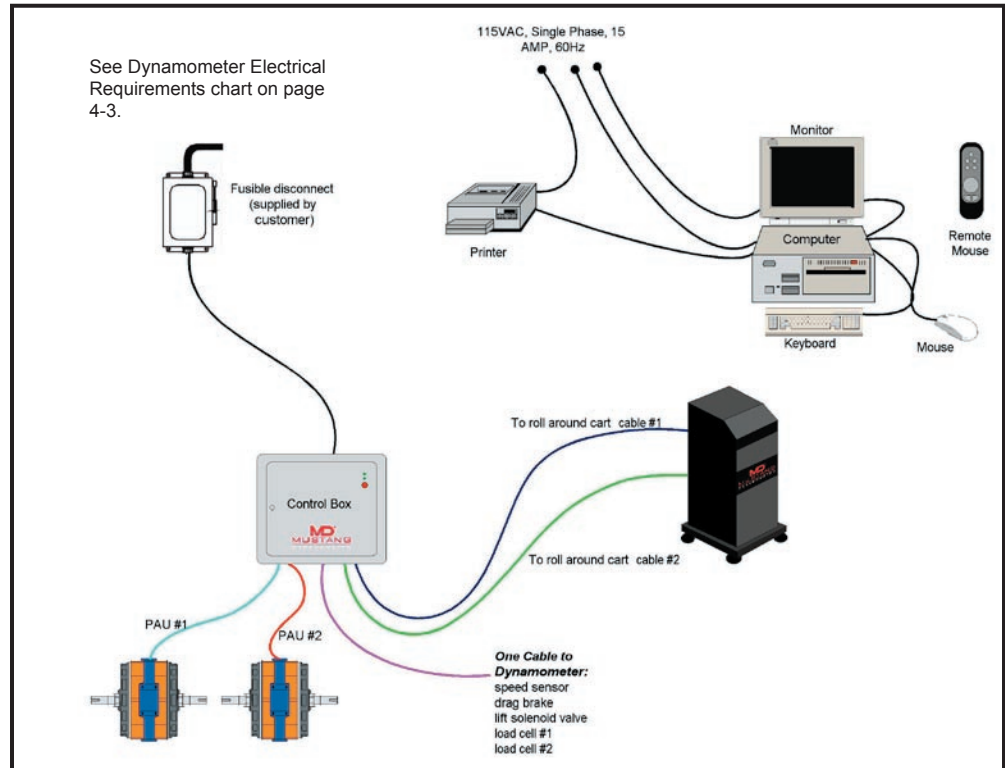

### 4.6.1 Control System Installation Procedure

1. Take the "dummy" load cell(s) out by removing the large bolts from the upper and lower load cell brackets. Attach the load cell on the lower bracket first. Upon completion, attach the load cell to the upper bracket. Tighten both bolts to 50 ft-lbs. Torque the eyelet bolt jam nuts to 200 in-lbs. **DO NOT OVERTIGHTEN !**

**NOTE:** Position the load cell so the wire is on the side opposite the Power Absorbing Unit.

2. Route cabling and air line. Leave enough slack in the cables and the air line so that the appropriate connection can be made.
3. After routing the air line, push the plastic air line into the quick release air fitting on the air solenoid until it is snug. **Make sure that the air line will not come into contact with the rolls.**

**FIG. 4.2**  
LIFT SOLENOID

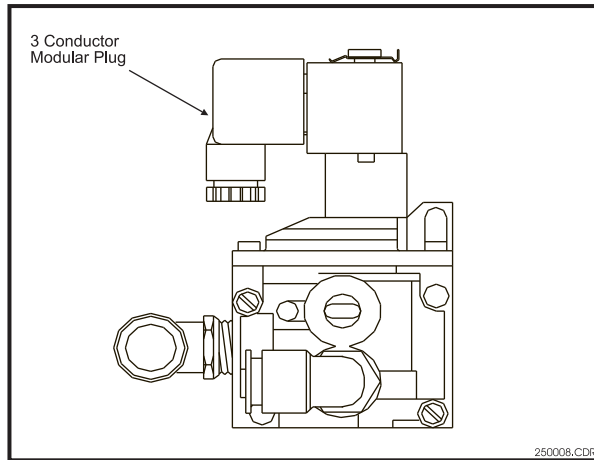

4. Attach the 3 conductor modular plug end of lift solenoid cable to the lift solenoid using a small screwdriver ( refer to Fig. 4.2 ).
5. Attach the cable with the 3 pin female connector to the speed magnetic pickup.
6. Attach the cable with the 4-Pin female connector to the load cell.
7. Connect PAU power cable to the eddy-current power absorber. White wire to PAU-, black wire to PAU+, and Green wire to chassis ground (refer to Fig. 4.3).
8. Install main air supply line to the tubing near the conduit run to the dyne. This air supply must have an in line air dryer and must be regulated between 80- 120 psi.

**FIG. 4.3**  
PAU WIRING

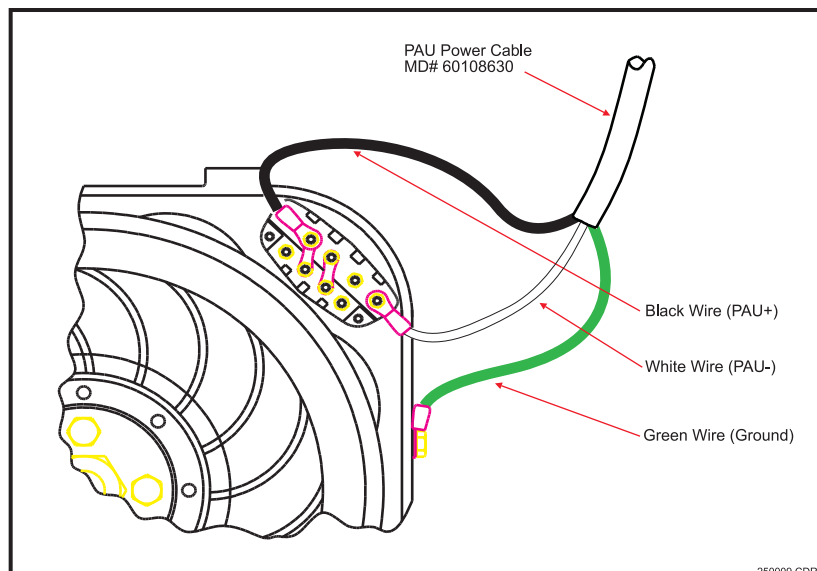



**Note:** Please refer to Fig. 4.1 and Fig. 4.4 for steps 9 through 14

**FIG. 4.4**  
COMPUTER  
CONNECTIONS

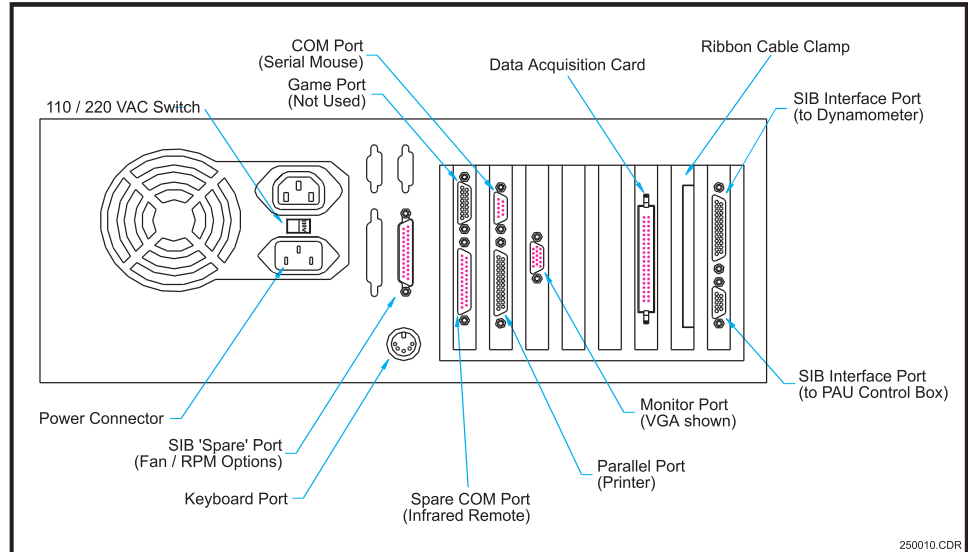

9. Connect monitor, keyboard, Mouse, and infrared receiver to the computer as labeled on the rear of the computer. **DO NOT CONNECT POWER TO THE COMPUTER AT THIS TIME !**
10. Connect Dynamometer Control cable DB-25 male connector to the DB-25 female connector on the rear of the computer labeled Dynamometer or Dyno.
11. Connect Drive Control cable DB-9 male connector to the DB-9 female connector on the rear of the computer labeled Control Box.
12. If purchased, connect printer, fan, and/or RPM meter to the appropriate labeled connectors on the rear of the computer.
13. Connect Drive Control cable CPC-24 female connector to the CPC-24 male connector labeled Drive Control on the Drive Control Box.
14. Connect PAU Power cable 3 conductor plug to connector labeled PAU on Drive Control Box.
15. Install main power input to the Drive Control Box as shown in Fig. 4.1 and Fig. 4.5. This circuit should come from the facility main supply box and must be a **FUSABLE DISCONNECT**. Power requirements are listed in Section 4.3.2 - Electrical.

**Note:** It is the customer's responsibility to ensure this circuit is installed according to all applicable building codes.

16. Plug computer, monitor, and printer (optional) into 120 VAC, single phase, 60 Hz, 10 Amp power.
17. Tie wrap all cables securely to prevent any cables from coming in contact with any moving part. Ensure no cabling is in contact with the PAU chassis.

**FIG. 4.5**  
DRIVE CONTROL BOX

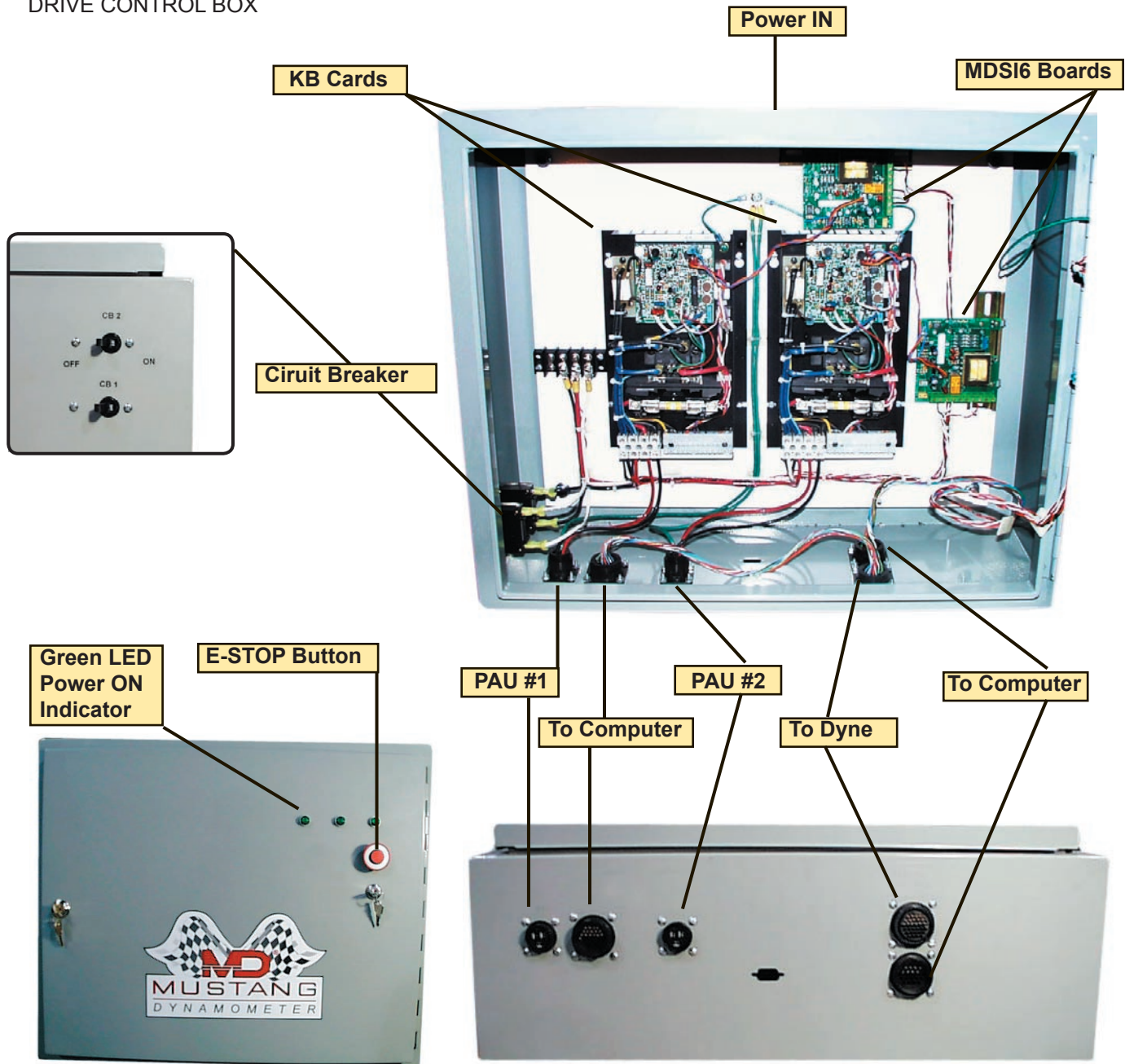



## 4.7 Pre-Operational Inspection

***WARNING: These procedures take at a minimum of 2 qualified personnel.***

***DO NOT PLUG THE SYSTEM INTO THE POWER SUPPLY.***

***DO NOT TURN ON SYSTEM OR HAVE A VEHICLE ON DYNAMOMETER.***

1. Verify the installation of the dynamometer meets all guidelines outlined in this manual. Do this NOW by reviewing the step by step installation procedures.
2. Verify the proper installation of the chain anchors.
3. Verify and check the torque of all the bolts and set screws to the specifications located in the Appendix. This procedure is very critical as some components may have loosened during shipping.
4. Verify all cable and air line connections are properly fastened, secured, and tightened.
5. Rotate dynamometer rollers by hand or foot ( a car should not be on at this time ) and verify they spin freely. The rollers will be somewhat difficult to spin due to the large mass that rotates.
6. Check to see that there is plenty of clearance around the rollers and that no components are rubbing, or are near rubbing.
7. Check all cabling and air lines to be sure that they are secured and clearly away from any rotating components.
8. Check the leveling of the dynamometer and ensure it is secured to the floor.
9. Clean up all installation tools in and around the dynamometer frame.



## CONTENTS

<b>5.1</b>	<b>Introduction</b> .....	<b>5-2</b>
<b>5.2</b>	<b>Initial Start</b> .....	<b>5-2</b>



## 5.1 Introduction

After the dynamometer has been installed according to the instructions presented in Section 4 - Installation, you should perform the operational checkout procedure given in this section to verify that the dynamometer is operating properly.

## 5.2 Initial Start-up

1. Be sure system is installed correctly as described in this manual.
2. Turn system ON with all components properly connected and linked to the computer. The system should boot up to the main menu screen.



**WARNING:** ***DO NOT DO ANY ADDITIONAL FUNCTIONS with the computer, stay in the main menu screen.***

3. Verify the air lines are routed to the proper locations and that the pressure is set between 80 - 120 psi. The air supply must be regulated and dried. Turn air supply on and check for leaks.



**WARNING:** ***BE SURE ALL EQUIPMENT AND PERSONNEL ARE CLEAR OF DYNAMOMETER.***

4. Activate the override roll lock switch on the side of the dyne control box. The rolls should lock.
5. Select a "REAR WHEEL DRIVE" vehicle for this Initial Start-up procedure. Check the vehicle crank case oil level, radiator level and automatic transmission fluid level (if applicable).
6. Ensure the vehicle tires are at their proper road pressure.
7. Be sure that there is no reason that the vehicle should not be operated on the dynamometer. If, for any reason, there are any doubts, **DO NOT RUN THE DYNAMOMETER**. Instead, please call a Mustang Dynamometer service engineer immediately.
8. Drive the vehicle onto the dynamometer. Be sure the vehicle is squared and centered on the rollers. If the vehicle is not squared and centered, drive off the dynamometer and repeat until the vehicle is squared and centered. Turn vehicle's engine off.
9. Unlock the rolls by turning the override switch on the side of the control box.
10. Start the vehicle, APPLY BRAKE, and put into a forward gear. SLOWLY release brake, or clutch if manual transmission, and rotate the tires very slowly (not to exceed 2 mph). After the vehicle is settled, apply brake, put vehicle into park, and turn engine off. This procedure should only take 10-15 seconds.

11. Make sure that the tires are clear of the dynamometer frame.
12. After the vehicle is positioned properly it is **MANDATORY** to secure the vehicle with straps.
13. Connect exhaust removal system.
14. Position the wheel chocks **IN FRONT** of the wheels that are not on the dynamometer.
15. The dynamometer is now ready for its first rotational break-in test.



**WARNING:** *The computer should still be in the main menu screen.*

16. Be sure all personnel and equipment are clear of the rotating dynamometer and that no personnel stand in front of the vehicle.
17. Start the engine and apply brake and/or clutch, place the vehicle in its drive gear or a low gear if a manual transmission.
18. Slowly release brake and/or clutch and check to see if the vehicle tires are rotating on the dynamometer. Do not exit your car, check with your assistant.



**WARNING:** ***DO NOT ACCELERATE VEHICLE: RUN AT IDLE. BE SURE ALL PERSONNEL ARE CLEAR OF VEHICLE.***

19. Run vehicle for 2-3 minutes.
20. Listen for noises, feel and look for vibration. Be sure vehicle does not sway left/right or back/front. Check for anything unusual.
21. Be sure the driver stays in the vehicle and all personnel stay clear of the dynamometer and of the front of the vehicle.
22. If there are any apparent problems, stop the procedure immediately.
23. If no problem occurs, accelerate vehicle in 10 mph increments up to 50 mph for 2-3 minutes at each increment.
24. Repeat steps 22, 23, 24 as required.
25. After running vehicle for 2-3 minutes at 50 mph, slowly apply brake and bring the vehicle to a stop, and put into park.
26. Release and remove all straps and move wheel chocks from the vehicle.
27. Activate override switch on the side of the interface box to lock rolls. Be sure all personnel are clear. Rolls should be locked.



28. Be sure exhaust ventilation system is clear. Remove vehicle from dynamometer.
29. Verify and check the torque of all the bolts and set screws to the specifications located in the Appendix.
30. IF YOU HAVE ANY QUESTIONS, Please do not hesitate to call our factory at (330) 963-5400.
31. This completes the basic start up rotational test of the equipment.

### CONTENTS

<b>6.1</b>	<b>Introduction .....</b>	<b>6-3</b>
<b>6.2</b>	<b>General Information .....</b>	<b>6-3</b>
<b>6.2.1</b>	<b>Pillow Block Bearings .....</b>	<b>6-3</b>
<b>(A.)</b>	<b>Expansion/Non-Expansion Bearings .....</b>	<b>6-3</b>
<b>(B.)</b>	<b>Locking Bearing to Shaft .....</b>	<b>6-4</b>
<b>6.2.2</b>	<b>Gear Tooth Couplings .....</b>	<b>6-4</b>
<b>6.3</b>	<b>Preventative Maintenance Time Table .....</b>	<b>6-6</b>
<b>6.4</b>	<b>Lubrication .....</b>	<b>6-7</b>
<b>6.4.1</b>	<b>General Information .....</b>	<b>6-7</b>
<b>6.4.2</b>	<b>Pillow Block Bearings .....</b>	<b>6-8</b>
<b>6.4.3</b>	<b>Couplings .....</b>	<b>6-9</b>
<b>6.4.4</b>	<b>Power Absorber .....</b>	<b>6-11</b>
<b>6.5</b>	<b>Inspection &amp; Adjustments .....</b>	<b>6-12</b>
<b>6.5.1</b>	<b>Check Torque of Bearing Set &amp; Hold Down Screws .....</b>	<b>6-12</b>
<b>6.5.2</b>	<b>Check Torque of Coupling Set Screw .....</b>	<b>6-12</b>
<b>6.5.3</b>	<b>Check Condition of Coupling Key .....</b>	<b>6-12</b>
<b>6.5.4</b>	<b>Check for Roll Lock Brake Pad Wear .....</b>	<b>6-12</b>
<b>6.5.5</b>	<b>Check Condition &amp; Tension of Belt .....</b>	<b>6-13</b>
<b>(A)</b>	<b>Condition Check .....</b>	<b>6-13</b>
<b>(B)</b>	<b>Tension Check .....</b>	<b>6-13</b>
<b>6.5.6</b>	<b>Power Absorbing Unit Checks .....</b>	<b>6-13</b>
<b>(A)</b>	<b>Check Bearing End Play .....</b>	<b>6-14</b>
<b>(B)</b>	<b>Check Rotor Air Gaps .....</b>	<b>6-14</b>
<b>6.6</b>	<b>Cleaning &amp; Corrosion Prevention .....</b>	<b>6- 15</b>
<b>6.6.1</b>	<b>Cleaning Your Machine .....</b>	<b>6-15</b>
<b>6.6.2</b>	<b>Cleaning The Pit (If Applicable) .....</b>	<b>6-15</b>
<b>6.6.3</b>	<b>Corrosion Prevention .....</b>	<b>6-15</b>



## LIST OF FIGURES

Fig. 6.1	Hub & Sleeve Gear Tooth Coupling .....	6-5
Fig. 6.2	Hub & Flange Gear Tooth Coupling .....	6-5
Fig. 6.3	Pillow Block Bearing Setscrews & Lube Point .....	6-8
Fig. 6.4	Coupling Setscrews, Lube & Relief Points .....	6-10
Fig. 6.5	PAU Lube & Relief Points .....	6-11
Fig. 6.6	PAU Checking Nomenclature .....	6-14

## LIST OF TABLES

Table 6.1	Preventative Maintenance Time Table .....	6-6
Table 6.2	Suggested Lubrication Period (in Weeks) .....	6-9

## 6.1 Introduction

Proper maintenance procedures performed on a regular basis are essential to the well-being of any machine. By establishing a preventative maintenance program and then adhering to it you can lower the risk considerably of finding your dynamometer inoperative just when you need it the most.

This section begins with a general discussion of the following mechanical components of the dynamometer:

- Pillow Block Bearings
- Gear Tooth Couplings

Later in this section a "Preventative Maintenance Time Table" is presented to give you an idea of the types of maintenance that will need to be performed and the frequency at which these activities should be performed. In addition, specific instructions are presented that provide more detailed maintenance information for various machine components.

## 6.2 General Information

### 6.2.1 Pillow Block Bearings

The Dynamometer's rolls, PAU, and inertia weight (optional) are supported by a combination of expansion and non-expansion types of both ball and high capacity double row spherical roller bearings

#### (A) Expansion/Non-Expansion Bearings

During the operation of your dynamometer, temperature changes may cause a linear expansion or contraction of the various components in the system. In a two pillow block arrangement (for example on a given roll), at least one non-expansion type of bearing is used as an anchor bearing to accommodate thrust loads and position peripheral equipment. The other pillow block may be of the expansion type to accommodate any expansion and contraction in the components. The bearings can be identified as follows:

***Expansion-type bearings...*** are identified by a small white metal disk installed under the grease fitting on the bearing's housing.

***Non-expansion bearings...*** will have either no disk under the fitting or a small blue metal disk under the fitting.

<b>CAUTION</b>	
	<p>If your dynamometer has not been operated for a long period of time (ex. 5 or 6 months) we strongly suggest that you manually rotate the rolls of the dyne for about 10 minutes prior to operating the unit.</p> <p>Doing so will enable the bearings to re-establish their self-alignment, thereby minimizing the likelihood of damaging your machine when it is operated under power.</p>

**(B) Locking Bearing To Shaft**

The inner race of each bearing is securely locked to the shaft on which they are mounted by means of two set screws in the bearing's collar.

### 6.2.2 Gear Tooth Couplings

Gear Tooth Couplings are used in the drive line of your dynamometer between major sub-assemblies (ex. rolls, PAU, etc.) for the purposes of transmitting torque and enabling the sub-assemblies to be easily removed from the Dyne and allowing for slight offset and angular misalignment as well as end float in drive line components.

Two types of gear tooth couplings are used on Mustang Chassis Dynamometers:

- *Hub and Sleeve*
- *Hub and Flange*

The performance and life of couplings depend largely upon how you install and maintain them. Also, the correct installation, alignment, and lubrication of the couplings is critical to the proper operation of your dynamometer.

**FIG. 6.1**  
HUB & SLEEVE  
GEAR TOOTH  
COUPLING

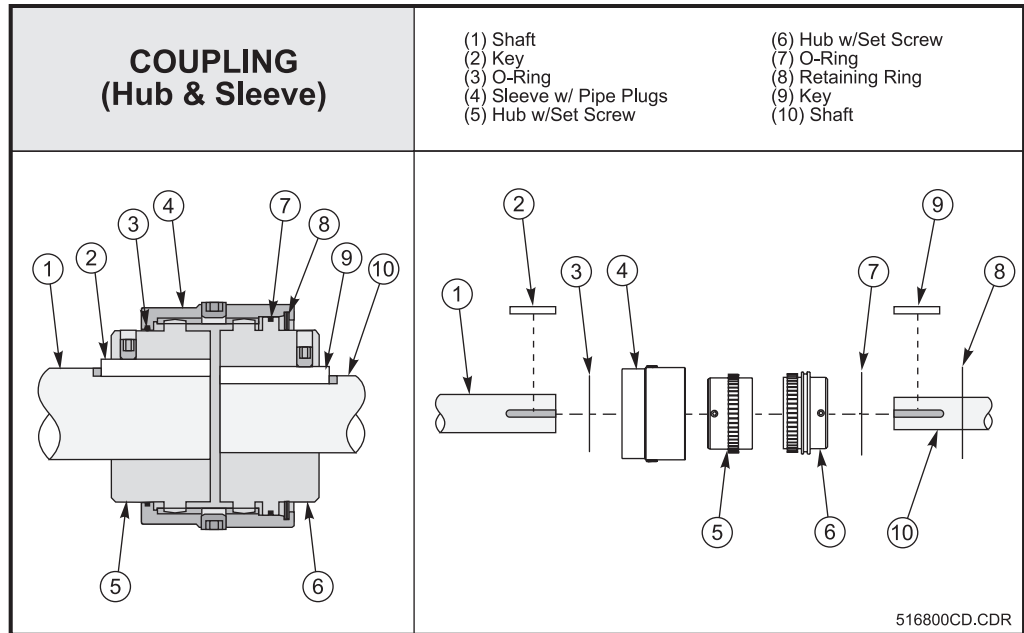

**FIG. 6.2**  
HUB & SLEEVE  
GEAR TOOTH  
COUPLING

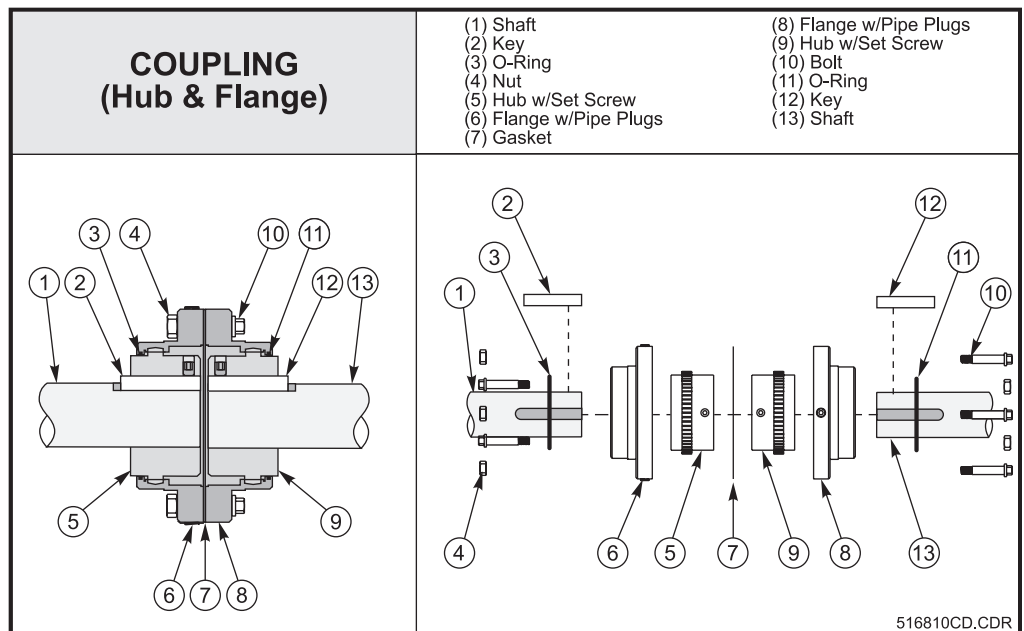



### 6.3 Preventative Maintenance Time Table

After the dynamometer has been installed according to the instructions presented in Section 4 - Installation, you should perform the operational checkout procedure given in this section to verify that the dynamometer is operating properly.

Table 6.1 Preventative Maintenance Time Table						
Maintenance Procedure	Break-in	Weekly	Monthly	3 Mo.	6 Mo.	Note
<b>Lubrication</b>						
Couplings			•			
PAU - Interenal Bearings			•			
Pillow Block Bearings			•			
<b>Inspection &amp; Adjustment</b>						
Bags - Air Lift			•			
Belt Tension	⊙		•			1
Bolts - All Structural	⊙		•			1
Brake Pads			•			
Speed Sensor			•			
Keys - Coupling			•			
Keys - Sprocket			•			
Lines - Air				•		
PAU - Bearing End Play					•	
PAU - Rotor Air Gaps					•	
Screw Torque - Pillow Block Bearing MITG.	⊙		•			1
Set Screw Torque - Couplings	⊙	⊙	•			2
Set Screw Torque - Pillow Block Bearings	⊙	⊙	•			2
Set Screw Torque - Sprockets	⊙	⊙	•			2
<b>Cleaning/Corrosion Prevention</b>						
Bright Metal Parts			•			
Dynamometer Pit			•			
<p>NOTES:</p> <p>1. After first 8 hours of operation and then monthly thereafter.</p> <p>2. After first 8 hours of operation, then after the first week of operation, and then monthly thereafter.</p> <p>* This preventative maintenance time table is based upon an average of 40 hours of machine usage per week. If your installation differs from this, please modify the time table accordingly.</p> <p>⊙ This represents a special operation; for more information, refer to appropriate note above.</p>						

## 6.4 Lubrication

### 6.4.1 GENERAL INFORMATION

Lubrication of the dyne's anti-friction bearings should be done as part of a planned maintenance schedule. The recommended lubrication interval given in the "Preventative Maintenance Time Table" should be used as a guide to establish this schedule.

<b>CAUTION</b>	
	<p>A lack of lubricant as well as using the wrong kind will reduce the bearing's life expectancy. Your Mustang Dynamometer was lubricated at the factory using the lubricants specified in the chart in the Appendix - "Recommended Fluids". We strongly suggest that you continue to maintain your machine using these same lubricants.</p>

Mixing lubricants is not recommended due to possible incompatibility. If you desire to change to other lubricants, follow all of the lubrication instructions provided in this manual and repeat lubrication a second time after 100 hours of service. Care must be taken to look for signs of incompatibility, such as extreme soupiness visible from grease relief areas.

<b>CAUTION</b>	
	<p>Cleanliness is important in lubrication. Any grease used to lubricate the anti-friction bearings should be fresh and free from contamination. Similarly, care should be taken to properly clean all lubrication inlet areas (ex. zerk fittings, fill holes, etc.) to prevent lubricant contamination.</p>

### 6.4.2 Pillow Block Bearing

Refer to the Appendix - "Recommended Fluids" and Fig. 6.3. The frequency at which you should lubricate the pillow block bearings that was given previously in the Preventative Maintenance Time Table was based upon an average amount of usage. If you feel that your usage is not average, please refer to Table 6.2 to determine a more appropriate lubrication interval.

<b>CAUTION</b>	
	<p><b>High Speed Operation</b> - In the higher speed ranges too much grease will cause overheating. The amount of grease the bearing will take for a particular high speed application can only be determined by experience. If excess grease in the bearing causes overheating, it will be necessary to remove the grease fitting to permit excess grease to escape. When establishing a relubrication schedule, note that a small amount of grease at frequent intervals is preferable to a large amount at infrequent intervals.</p> <p>It is very important that the pillow block bearings not be over-greased. Over-greasing the bearings can change the parasitic losses of the dynamometer.</p>

Using a hand pump grease gun filled with a No. 2 lithium based grease (ex. Mobilith AW 2), insert the grease gun into the zerk fitting located either on the lubrication distribution block (if installed) or near the top of the pillow block bearing. Pump the handle while rotating the rolls until grease appears at the bearing seals. Remove any excess grease.

**FIG. 6.3**  
PILLOW BLOCK BEARING SET SCREW & LUBE POINT

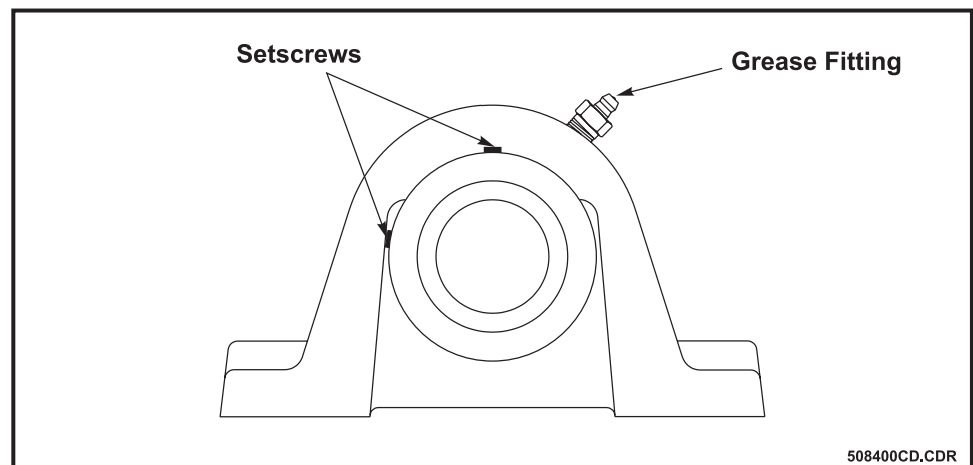

**Table 6.2 Suggested Lubrication Period (in weeks)**

Hours Run Per Day	Typical Operating Range (RPM)							
	1 to 250	251 to 500	501 to 750	751 to 1000	1001 to 1500	1501 to 2000	2001 to 2500	2501 to 3000
8	12	12	7	7	5	4	3	2
16	12	7	4	4	2	2	1	1
24	10	5	2	2	1	1	1	1

Source: Instruction Manual 499498, September, 1992; Dodge/Reliance Electric Company

NOTE: For the MD-100, every mile per hour that the rolls rotate corresponds to 33.3 rpm. For the MD-250, 31.4 rpm should be used. For example, if the average speed over 8 hours on a standard MD-250 is 40 mph, then the typical operating range will be (40 mph x 31.4 rpm/mph) = 1256 rpm suggesting that you lubricate the bearings every 5 weeks.

### 6.4.3 Couplings

Refer to the Appendix - "Recommended Fluids" and Fig. 6.4.

	CAUTION
<p>The high centrifugal forces encountered in couplings separate the base oil and thickener of general purpose greases. Heavy thickener, which has no lubrication qualities, accumulates in the tooth mesh area of gear couplings resulting in premature mesh failure unless periodic lubrication cycles are maintained.</p>	

Remove a top and bottom plug from one of the coupling hub flanges located on the circumference of the coupling sleeve (or flange) and then insert a 1/2" NPT zerk fitting into one of the holes (this can be temporarily removed from one of the bearings). Using a hand pump grease gun filled with a multi-purpose grease, pump the handle until grease comes out of one of the other holes. Insert a plug in this hole. Repeat this process until all of the holes are plugged. Then, remove the zerk fitting and then re-install the hole plug. Tighten all the plugs until they are snug - **DO NOT OVER-TIGHTEN THE PLUGS.**

**NOTE:** The coupling grease requirements are as follows:

- Hub & Sleeve style coupling ... about 1 ounce
- Hub & Flange style coupling ... about 2.5 ounces



**FIG. 6.4**  
COUPLING SET  
SCREWS, LUBE &  
RELIEF POINTS

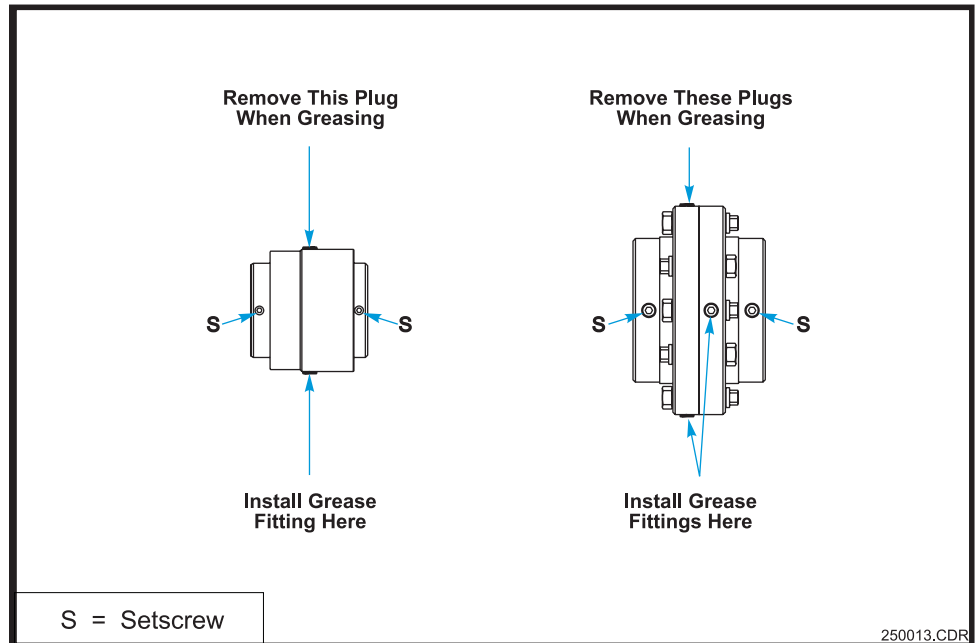

## 6.4.4 Power Absorber

Refer to the Appendix - "Recommended Fluids" and Fig. 6.5.

Wipe off any dirt or other contaminants that may be on the PAU's zerk fitting. Using a hand pump grease gun filled with a lithium complex synthetic grease, insert the nipple into the zerk fitting located on the top of the power absorber. Pump the handle while rotating the power absorber until grease appears at the bottom of the power absorber relief point. Remove any excess grease and then re-install the relief plug.

**Note:** Some PAU's are sealed for life. Thus, they do not have a zerk fitting installed for lubrication.

**FIG. 6.5**  
PAU LUBE & RELIEF  
POINTS

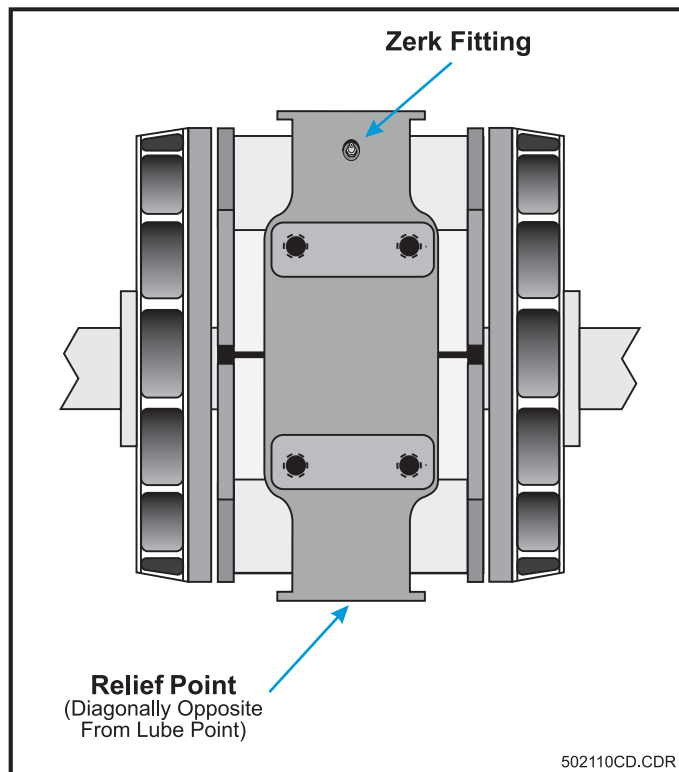

## 6.5 Inspection & Adjustments

<b>CAUTION</b>	
	<p>Loctite® 262 has been used on all set screws. If you remove any set screws you must re-apply Loctite® 262 prior to reinstalling them.</p> <p>Do not use an excessive amount of Loctite® 262 on a set screw; about 1/2 drop is usually sufficient to lock the set screw.</p>

### 6.5.1 Check Torque of Bearing Set & Hold Down Screws

Refer to the Appendix - "Torque Specifications" for appropriate torque values.

### 6.5.2 Check Torque of Coupling Set Screw

Refer to the Appendix - "Torque Specifications" for appropriate torque values.

### 6.5.3 Check Condition of Coupling Keys

Each coupling hub is prevented from rotating on its shaft by a square key (either 3/8" or 1/2" square). For each coupling, determine if its key is worn by grabbing each of the corresponding coupled rolls and rotating them in opposite directions. If you observe an excessive amount of play, the key and/or the coupling hub may need to be replaced.

### 6.5.4 Check for Roll Lock Brake Pad Wear

You can check the roll lock brake pads for signs of wear and deterioration by first lowering the lift plate and then inspecting the brake pads. If the average brake pad thickness is less than 1/8" or any spot on the pad is less than 1/16" thick, the brake pad will have to be replaced.

<b>WARNING</b>	
	<p>When performing this inspection, make sure that the air lift will not be accidentally raised.</p> <p>After the lift has been lowered, we strongly suggest that you turn off the supply air to the dynamometer until after you have completed the inspection.</p>

### 6.5.5 Check Condition & Tension of Belts

#### (A) Visual Check

Visually inspect the toothed drive belt to ensure that there are no signs of wear, damage, or deterioration.

#### (B) Tension Check

The tension applied to the belt that connects the rolls should be sufficient to prevent the belts from "jumping teeth" on the sprockets.

As a rule-of-thumb only, a properly tensioned belt can be rotated approximately 45° when it is grasped and twisted at a point on the belt which is midway between the two sprockets.

<b>CAUTION</b>	
	Toothed drive belts (also called synchronous belts) are not to be tensioned as you would a V-belt or any other belt that depends upon friction to transmit the load. They should be installed with a snug fit, neither too taut or too loose. Excessive toothed belt tension can lead to increased belt and bearing wear.

### 6.5.6 Power Absorbing Unit Checks

<b>WARNING</b>	
	When performing this inspection, make sure that the air lift will not be accidentally raised.  After the lift has been lowered, we strongly suggest that you turn off the supply air to the dynamometer until after you have completed the inspection.

### (A) Check Bearing End Play

1. Refer to Fig. 6.6. Measure the air gap between the rotor and a pole shoe with the rotor forced away from the pole shoe by means of two pry bars (ex. screw drivers) located 180° away from each other and 90° away from the pole shoe being checked. Measure the gap with a feeler gauge.
2. Measure the air gap between the same rotor and the same pole shoe, but with the rotor moved towards the pole shoe by two pry bars (ex. screw drivers) inserted in the air gap on the other side of the power absorber. Do not rotate the rotor when making the above two checks. Place a chalk mark on the pole shoe to prevent accidental rotating of the rotor.
3. The difference between the above two readings is the bearing end play. This value should not exceed 0.005". If the bearing end play exceeds 0.005" contact the factory for adjusting instructions.

### (B) Check Rotor Air Gaps

1. Refer to Fig. 6.6. Using feeler gauges, measure and average all eight (8) air gaps on each side of the power absorber. The average air gap measurement per side should be between .053" and .057" for MD-250 series dynamometers, and between .033" and .037" for MD-100 series models.
2. If the average air gap is out of range, contact a Mustang Dynamometer

**FIG. 6.6**  
PAU CHECKING  
NOMENCLATURE

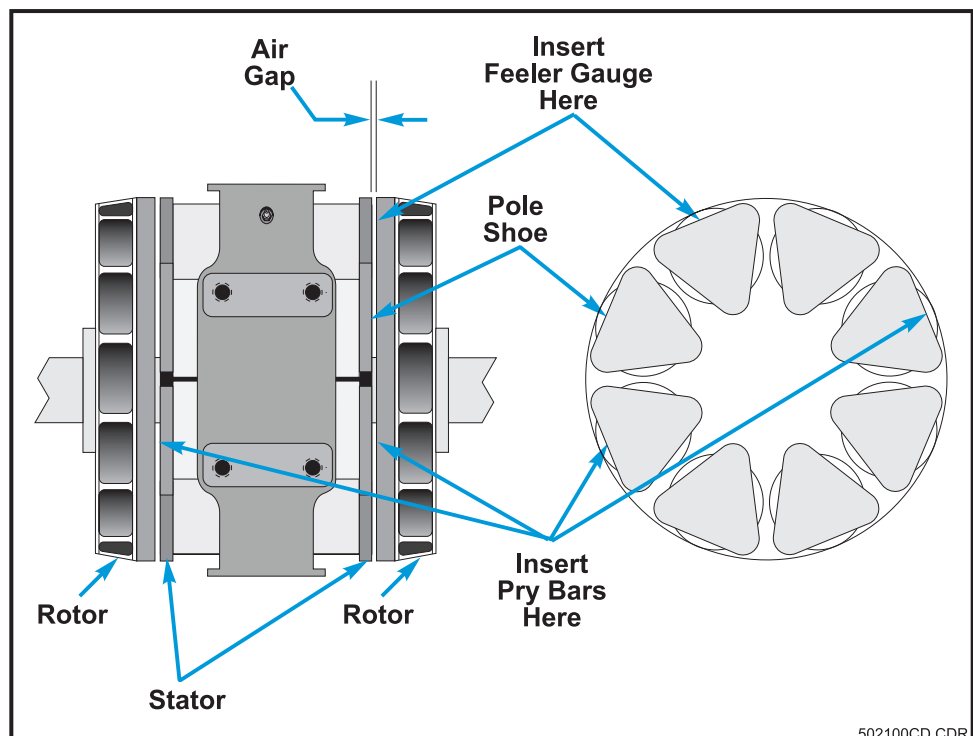

## 6.6 Cleaning & Corrosion Prevention

### 6.6.1 Cleaning Your Machine

	<b>CAUTION</b>
	You should never use pressurized water or compressed air to clean your machine since doing so may force contaminants into the machine's bearings.

When cleaning your machine you should only use a cloth that has been lightly wetted with either water or a mild grease/oil/tar remover. After cleaning bright metal parts be sure to apply a coating of corrosion preventative. For more information, please refer to the Appendix, "Recommended Fluids".

	<b>CAUTION</b>
	Special attention should be paid to the air bags and the areas surrounding them since a built-up dirt here could cause wear which, in turn, could lead to premature air bag failure.

### 6.6.2 Cleaning The Pit (If Applicable)

The pit in which your dynamometer has been installed should be cleaned of all foreign objects and debris. A small paint scraper can be used to loosen any of the built-up dirt; a "shop vac" can be used to pick up any of the smaller debris. Any excessive grease that may have been thrown from moving parts should be wiped clean. Also make sure the drains are clear to avoid water from collecting and causing corrosion.

### 6.6.3 Corrossion Prevention

Refer to the Appendix - "Recommended Fluids".

After cleaning your machine, be sure to use an anti-corrosive spray on all exposed bare metal to prevent rusting or other forms of corrosion from damaging it.



## CONTENTS

<b>7.1</b>	<b>Introduction .....</b>	<b>7-2</b>
<b>7.2</b>	<b>Troubleshooting Guide .....</b>	<b>7-3</b>



## 7.1 Introduction

This section of the manual presents information and procedures that will be beneficial to you if you encounter a problem with your dynamometer.

The "Troubleshooting Guide" is provided to help you quickly diagnose and correct problems of a general nature that may arise.

If you encounter a problem with your dynamometer, please don't panic. Quite often "problems" are the result of something very minor such as forgetting to apply air pressure to the dyne or cables that are not connected. When you begin troubleshooting, if appropriate to the problem being observed, check the obvious first. If this does not correct the problem for you, then consult the information presented in this section of the manual. If you are still unable to correct the problem and you have exhausted all possibilities, please feel free to contact a Mustang Service Engineer.



## 7.2 Troubleshooting Guide

Troubleshooting Guide		
I. Roll Set		
Problem	Possible Cause	Correction
Vibration and/or Noise	Structural frame of dyne is not secured to pit floor.	Check anchor bolts on dynamometer frame and tighten to proper specifications.
	Dynamometer is not level to the floor.	Level dyne and be sure shims are in place under frame where needed.
	Roll coupling is out of tolerance or alignment.	Repair or re-align according to factory instructions.
	Coupling between rolls, between roll and PAU, or between PAU and inertia weight assembly is worn.	Replace coupling according to factory instructions.
	Roll pillow block bearings not secured to frame.	Tighten bolts to proper specifications.
	Bearing failure on rolls.	Replace bearings according to factory instructions.
	Roll has spun on bearing and is worn.	Replace bearings according to factory instructions.
	Roll is out of balance.	Check roller shaft for wear. Normally needs new roll or tighten set screws on bearing.
	Inertia weight is out of balance	Check for loose weights on roll. Replace inertia weight assembly.
Bearing failure on inertia weight assembly	Replace bearings according to factory instructions.	



Troubleshooting Guide

II. Air Lift System

Problem	Possible Cause	Correction
Lift Fails to Lower	Platform override switch in "UP" position.	Turn Platform Override keyswitch to the "DOWN" position.
Lift Fails to Raise	Air supply to dynamometer has not been turned on.	Turn on air supply. Dry air, regulated to a MAXIMUM of 80 PSI, must be furnished to the dynamometer.
	Air lift solenoid coil has failed.	Check for +12 VDC across Pins 8 & 9 in Control Unit. If necessary, replace solenoid coil.
	Air lift solenoid-actuated valve has failed.	Replace valve.
	Power supply failing to operate properly.	Check (a) all connections in control unit and (b) solenoid valve cable. If necessary, repair or replace defective component.
	Air bag has ruptured.	Replace air bag.
	Roll speed other than zero is being displayed.	Trouble shoot speed sensor and wiring.
	Low air pressure.	Adjust dry, regulated air pressure furnished to dynamometer to a MAXIMUM of 80 PSI.
	Defective or improperly wired air pressure switch.	Verify correct wiring and test opening and closing of pressure switch contacts.
	Defective cable or connector.	Inspect all electrical wiring and replace any defective cables and/or connectors.
	Digital enable signal from host computer is not present.	Troubleshoot software system. Troubleshoot Dynamometer Control Unit.
Rolls Do Not Lock	Brake pads are worn.	Replace brake pads.
	Air leak in pneumatic system.	Inspect and replace any defective tubing, connectors, and/or air bags.
	Pins at air lift pivot points missing.	Replace missing pins and hair pin clips.
	Low air pressure.	Adjust dry, regulated air pressure furnished to dynamometer to a MAXIMUM of 80 PSI.



## Troubleshooting Guide

### III. Operational Problems

Problem	Possible Cause	Correction
Display Values Not Stable (i.e., Floating, Fluctuating, etc.)	Loose interface connection	Make sure that all cable connectors are properly seated. Verify that all connections inside the junction box are secure.
	Bad load cell connection	Check and, if necessary, repair all load cell connections.
No Speed Readout	Bad electrical connection.	Check all electrical connections in the system.
	Incorrect Magnetic Pickup to gear air gap.	Verify that air gap is set to .020".
	Magnetic Pickup failure.	Replace Magnetic Pickup.



## CONTENTS

**Appendix A - Torque Specifications**

**Appendix B - Recommended Fluids**

**Appendix C - Anchor Pod Installation - New Floors**



## Appendix A - Torque Specifications

TORQUE SPECIFICATIONS	FLEXIBLE DISC COUPLING BOLTS
BOLT SIZE	TORQUE
1/4-28	155 in.-lbs. 17.5 Nm
5/16-24	25 ft.-lbs. 33.9 Nm
3/8-24	30 ft.-lbs. 40.7 Nm
7/16-20	40 ft.-lbs. 54.2 Nm
1/2-20	95 ft.-lbs. 128.7 Nm
9/16-18	130 ft.-lbs. 176.2 Nm
5/8-18	175 ft.-lbs. 237.1 Nm
11/16-16	200 ft.-lbs. 271 Nm
3/4-16	260 ft.-lbs. 352.3 Nm
7/8-14	350 ft.-lbs. 474.3 Nm
1-14	335 ft.-lbs. 453.9 Nm

TORQUE SPECIFICATIONS	BEARING MOUNTING BOLTS
BOLT SIZE	TORQUE
3/8-16	20 ft.-lbs. 27.1 Nm
1/2-13	50 ft.-lbs. 67.8 Nm
5/8-11	100 ft.-lbs. 135.5 Nm
3/4-10	175 ft.-lbs. 237.1 Nm
7/8-9	200 ft.-lbs. 271 Nm
M10 1.5	20 ft.-lbs. 27.1 Nm
M12 1.75	35 ft.-lbs. 47.4 Nm
M16 2	90 ft.-lbs. 122 Nm
M20 2.5	175 ft.-lbs. 237.1 Nm
M22 2.5	235 ft.-lbs. 318.4 Nm

TORQUE SPECIFICATIONS	BEARING SET SCREWS (ANSI B18.3-1986, BS 4168-1981)	
SET SCREW SIZE	TORQUE	HEX KEY SIZE
#10-32	30 in.-lbs. 3.4 Nm	3/32
1/4-28	75 in.-lbs. 8.5 Nm	1/8
5/16-24	140 in.-lbs. 15.8 Nm	5/32
3/8-24	250 in.-lbs. 28.2 Nm	3/16
1/2-20	50 ft.-lbs. 67.8 Nm	1/4
5/8-18	110 ft.-lbs. 149 Nm	5/16
M5 0.8	30 in.-lbs. 3.4 Nm	2.5 mm
M6 1	60 in.-lbs. 6.8 Nm	3 mm
M8 1.25	140 in.-lbs. 15.8 Nm	4 mm
M10 1.5	250 in.-lbs. 28.2 Nm	5 mm
M12 1.75	40 ft.-lbs. 54.2 Nm	6 mm

TORQUE SPECIFICATIONS	COVER PLATE BOLTS (ANSI B18.3-1986, BUTTON HEAD CAP SCREWS)	
BOLT SIZE	TORQUE	SOCKET SIZE
3/8-16	15 ft.-lbs. 20.3 Nm	7/32
1/2-13	35 ft.-lbs. 47.4 Nm	5/16
5/8-11	70 ft.-lbs. 94.9 Nm	3/8



# MD-1750 Chassis Dynamometer Maintenance & Service Manual

## TAPERED QD-STYLE BUSHING BOLTS

TORQUE SPECIFICATIONS	PLAIN BUSHING	TORQUE SPECIFICATIONS	IDLER BUSHING w/BEARINGS
BOLT SIZE	TORQUE	BOLT SIZE	TORQUE
#10-24	60 in.-lbs. 6.8 Nm	1/4-20	60 in.-lbs. 6.8 Nm
1/4-20	110 in.-lbs. 12.4 Nm	5/16-18	95 in.-lbs. 10.7 Nm
5/16-18	180 in.-lbs. 20.3 Nm	3/8-16	15 ft.-lbs. 20.3 Nm
3/8-16	30 ft.-lbs. 40.7 Nm	1/2-13	30 ft.-lbs. 40.7 Nm
1/2-13	60 ft.-lbs. 81.3 Nm		
9/16-12	75 ft.-lbs. 101.6 Nm		
5/8-11	135 ft.-lbs. 182.9 Nm		
3/4-10	225 ft.-lbs. 304.9 Nm		
7/8-9	300 ft.-lbs. 406.5 Nm		
1-8	450 ft.-lbs. 609.8 Nm		

TORQUE SPECIFICATIONS	GENERAL MOUNTING BOLTS (STANDARD ANSIB18.2.1-1981, HHCS SAE 5 OR BETTER w/WASHERS) (METRIC ANSIB18.2.2.1M-1979, HHCS GRADE 8.8 OR BETTER w/WASHERS)			
BOLT SIZE	TORQUE	BOLT SIZE	TORQUE	SOCKET SIZE
1/4-20	100 in.-lbs. 11.3 Nm	1/4-28	110 in.-lbs. 12.4 Nm	7/16
5/16-18	200 in.-lbs. 22.6 Nm	5/16-24	215 in.-lbs. 24.3 Nm	1/2
3/8-16	30 ft.-lbs. 40.7 Nm	3/8-24	30 ft.-lbs. 40.7 Nm	9/16
7/16-14	45 ft.-lbs. 61 Nm	7/16-20	50 ft.-lbs. 67.8 Nm	5/8
1/2-13	70 ft.-lbs. 94.9 Nm	1/2-20	75 ft.-lbs. 101.6 Nm	3/4
9/16-12	100 ft.-lbs. 135.5 Nm	9/16-18	110 ft.-lbs. 149.1 Nm	13/16
5/8-11	135 ft.-lbs. 182.9 Nm	5/8-18	150 ft.-lbs. 203.3 Nm	15/16
3/4-10	240 ft.-lbs. 352.2 Nm	3/4-16	265 ft.-lbs. 359.1 Nm	1 1/8
7/8-9	390 ft.-lbs. 528.5 Nm	7/8-14	420 ft.-lbs. 569.1 Nm	1 5/16
1-8	585 ft.-lbs. 792.7 Nm	1-12	620 ft.-lbs. 840.1 Nm	1 1/2
M6 1	85 in.-lbs. 9.6 Nm	M6 0.75	95 in.-lbs. 10.7 Nm	10 mm
M8 1.25	210 in.-lbs. 23.7 Nm	M8 1	225 in.-lbs. 25.4 Nm	13 mm
M10 1.5	35 ft.-lbs. 47.4 Nm	M10 1.25	35 ft.-lbs. 47.4 Nm	16 mm
M12 1.75	60 ft.-lbs. 81.3 Nm	M12 1.25	65 ft.-lbs. 88.1 Nm	18 mm
M14 2	95 ft.-lbs. 128.7 Nm	M14 1.5	105 ft.-lbs. 142.3 Nm	21 mm
M16 2	150 ft.-lbs. 203.3 Nm	M16 1.5	160 ft.-lbs. 216.8 Nm	24 mm
M20 2.5	295 ft.-lbs. 399.7 Nm	M20 1.5	325 ft.-lbs. 440.4 Nm	30 mm
M24 3	505 ft.-lbs. 684.3 Nm	M24 2	555 ft.-lbs. 752 Nm	36 mm

# MD-1750 Chassis Dynamometer Maintenance & Service Manual



TORQUE SPECIFICATIONS	POWER ABSORBER FASTENERS
TYPE	TORQUE
Main Shaft Nut	
K-40 to K-160	325 ft.-lbs. 440 Nm
K-200 to K-480	470 ft.-lbs. 640 Nm
K-70 CHI	470 ft.-lbs. 640 Nm
<hr/>	
Flange to Rotor Bolts	
K-40 to K-160	150 ft.-lbs. 205 Nm
K-200 to K-480	200 ft.-lbs. 275 Nm
<hr/>	
Flange Bolts	
Size 1410 Flange	85 ft.-lbs. 120 Nm
Size 1600 Flange	50 ft.-lbs. 70 Nm
<hr/>	
Pole Plate Bolt	
K-40 to K-160	50 ft.-lbs. 70 Nm
K-200 to K-480	85 ft.-lbs. 120 Nm
<hr/>	
Seal Plate Bolts	85 in.-lbs. 9 Nm
<hr/>	
Terminal Block Nuts	
M5	20 in.-lbs. 1.95 Nm
M6	30 in.-lbs. 3.43 Nm



## Appendix B - Recommended Fluids

### RECOMMENDED FLUIDS

MD PART NUMBER	MANUFACTURER	DESIGNATION	DESCRIPTION
Grease			
20010651	Mobil	Mobilith AW2	Used in all general bearings.  Multi-purpose, lithium-complex grease; excellent protection against rust and corrosion smooth and tacky, green in color
Oil			
20010653	Mobile	SHC 634	Used in all gear boxes.
Corrosion Preventative			
20014736	Sprayon	#710 PDRP	Used on all bright metal parts.  A heavy duty water displacing film that provides great protection in salt water and high humidity atmosphere; does not contain silicon; will penetrate and lubricate non-accessible areas. Easily removed with petroleum solvents.
Adhesive			
20010654	Loctite	Loctite 262	Permanent threadlocker.



## Appendix C - Anchor Pod Installation - New Floors

The procedure given below should be followed when you want to install anchor pods in a floor that is going to be poured.

NOTE: The frame numbers in the illustration correspond to the procedure steps below.

[1] Using the butt-end of a sledge hammer, tap on the anchor expander wedge until it breaks loose from the sleeve.

[2] Place the anchor sleeve on its side on a hard surface. Using a hammer, strike each of the four slotted section ends until the diameter of the sleeve has been reduced enough so the floor plate can slide easily over the sleeve.

[3] Install the floor plate over the slotted end of the sleeve until it is about 1/3 of the way onto the anchor. When properly positioned, 1/2" to 3/4" of the slot should remain below the floor plate.

[4] Place the anchor expander wedge back into the sleeve and strike it with a hammer until the anchor expander wedge is secured. When properly installed, about 1/4" of the wedge will be exposed at the bottom of the sleeve.

[5] Install the chain and the retainer wedge into the base of the anchor expander wedge. Make sure that only one link of the chain extends below the expander wedge.

[6] Wad up one full size sheet of newspaper for the outside base of the anchor and one for the inside top of the anchor. Tape the wad of newspaper fully onto the base so concrete will not contact the underside of the anchor and seize the chain after it has cured. This measure will ensure that the chain can, if necessary, be removed at a later time.

[7] Fully tape all slots so concrete will not seep into the anchor during the pouring operation. The wad of newspaper inside the top portion of anchor is added insurance against seepage of concrete into anchor interior. Turn the anchor pod lid (not illustrated) upside down so the logo is facing inwards and then tape the lid securely onto the anchor. The anchor is now ready to be set into place.

[8] Lay out the desired anchor pod locations. When properly installed, the top of each anchor should be level with the finished concrete. Install a string above each anchor pod to represent the final concrete level.

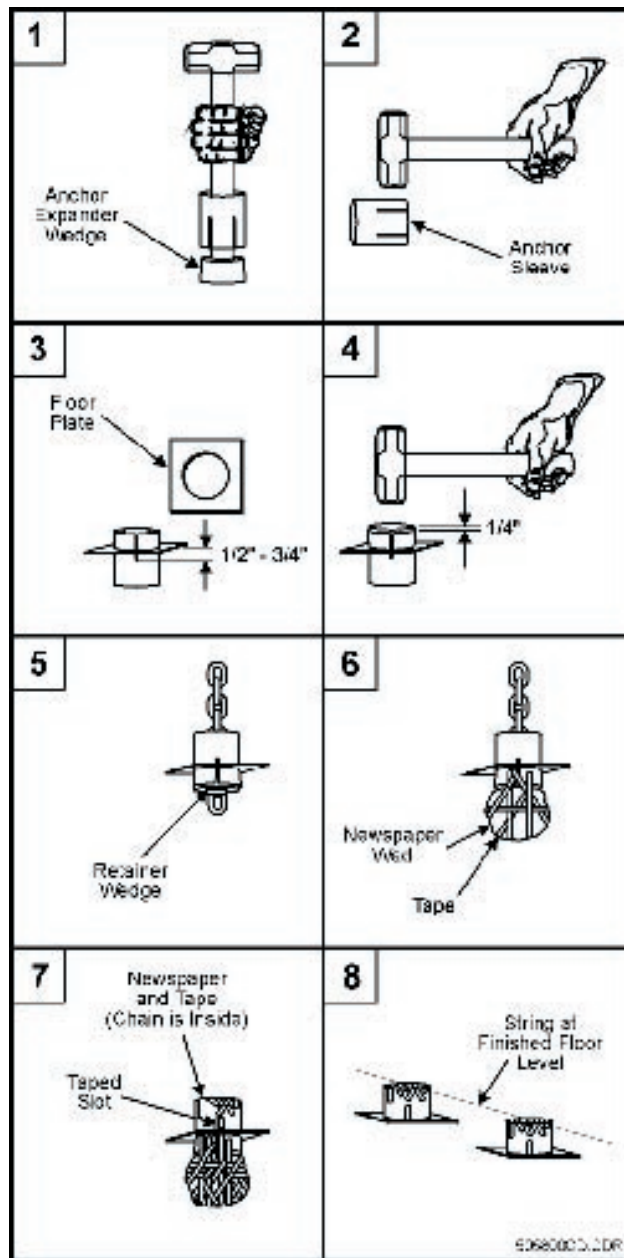

**CAUTION:** Allow the new concrete floor to cure for 11 weeks before pulling on the anchors. The newspaper wrapped under the anchor will decompose, leaving access for chain removal



# MD-1750 Chassis Dynamometer Maintenance & Service Manual





# Specifications

## MD-1750

## High Performance Chassis Dynamometer

<b>Horsepower:</b>	1,750 hp maximum measurement capability
<b>DE Model:</b>	800 hp peak absorption
<b>SE Model:</b>	400 hp peak absorption
<b>Loading:</b>	Air cooled eddy current power absorbers (MDK-250)
<b>Maximum Speed:</b>	225 mph
<b>Inertia:</b>	
<b>DE Model:</b>	2,688 lbs equivalent base mechanical inertia
<b>SE Model:</b>	5,530 lbs equivalent base mechanical inertia
<b>Inertia Model:</b>	2,370 lbs equivalent base mechanical inertia
<b>Controls:</b>	Pentium-based PC MD-7000 Control Platform with Virtual Inertia™ Technology
<b>Hand Control:</b>	Infrared, for remote operation
<b>Rolls:</b>	Precision machined & dynamically balanced 50" diameter roller per wheel 28" face length (26" knurled) 28" inner track width 84" outer track width
<b>Frame:</b>	Heavy-duty structural steel frame
<b>Restraints:</b>	In-ground units supplied with (12) anchor pods. Above-ground units supplied with rear tie-down restraints. All units include (4) 10,000 lb, 10' long ratchet straps; (2) Axle straps; and (2) wheel chocks.
<b>Roll lock:</b>	Industrial brake pad in contact with O.D. of roll
<b>Roll Decelerator:</b>	Allows dynamometer deceleration without use of vehicle brakes Eddy Current PAUs also used to decelerate rollers
<b>Air Requirements:</b>	80 PSI, dry, regulated, oil free
<b>Power Requirements:</b>	115 VAC, single phase, 60 Hz, 15 Amps (computer)
<b>DE Model:</b>	230 VAC, three phase, 60 Hz, 40 Amps (dynamometer)
<b>SE Model:</b>	230 VAC, three phase, 60 Hz, 20 Amps (dynamometer)
<b>Inertia Model:</b>	NA
<b>Axle Weight:</b>	10,000 lbs maximum
<b>Drive-Over Capacity:</b>	10,000 lbs maximum
<b>Shipping Weight:</b>	11,500 lbs (dynamometer weight only)

- Specifications subject to change without notice
- Maximum power rating based on proper tire to roll contact and correctly restrained vehicle
- Specifications may vary depending on model variations and specified options.



2300 Pinnacle Parkway  
Twinsburg, Ohio 44087 USA  
Ph: (330) 963-5400  
Fax (330) 425-3310

[www.mustangdyne.com](http://www.mustangdyne.com)