

MD-AWD-150

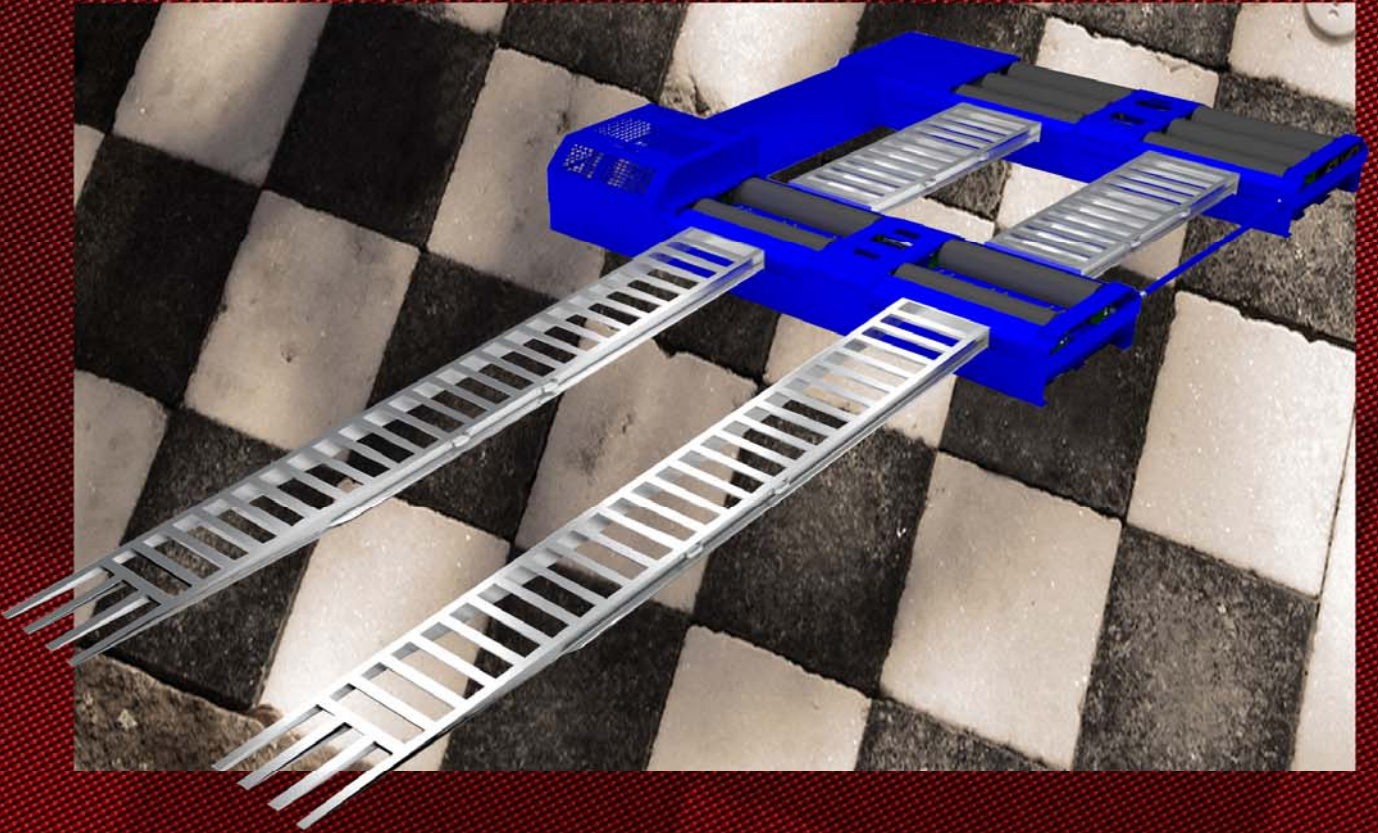

MD
MUSTANG

DYNAMOMETER

Information in this document is subject to change without notice. No part of this document may be reproduced or transmitted in any form or by any means, electrical or mechanical, for any purpose, without the express written permission of Mustang Dynamometer.

Copyright 2012
Ganzcorp Investments, inc. dba Mustang
Dynamometer
All rights reserved

NOTICE

This manual has been designed and written to provide useful information about Mustang Dynamometer equipment and systems. Every effort has been made to make this manual as complete and accurate as possible, but no warranty or fitness is implied.

The information contained in this manual is provided on an "as is" basis. Neither the author of this manual nor the management and owners of Mustang Dynamometer shall have either liability or responsibility to any person or entity with respect to any loss or damages arising from the information contained in this manual

Rev. B May, 2013

L WARNING L

Do not operate or perform any maintenance on you equipment until you have carefully read this manual in its entirety making sure that you understand all of the material presented in each section.

L WARNING L

Unsafe operation practices can lead to potentially dangerous situations when your machine is running.

Only properly trained and responsible personnel should attempt to operate this machine.

L WARNING L

Removal and disassembly instructions in this manual have been reduced to a minimum for ease of readability.

Only experienced maintenance personnel should attempt to install and/or make repairs to this machine.

L WARNING L

Keep limbs, hair, jewelry and clothing away from the moving rolls. When operating a vehicle on the machine, remain inside the vehicle until the rolls have stopped, Cover the rolls when the equipment is not in use.



WARNING LIMIT OF LIABILITY

Mustang warrants that the product(s) that is the subject of this sale is free from defects in material. The duration of this warranty is one year from date of shipment of all Mustang-related components. Components not manufactured by Mustang will carry the original manufacturer's warranty, typically 90 days for all electronic-related components. All warranty claims must be processed through Mustang.

If a problem arises within the applicable warranty period, it is the responsibility of the purchaser to (a) promptly notify Mustang in writing (b) obtain a RMA Number from Mustang (c) return to Mustang the component(s) that are claimed to be defective (transportation charges must be prepaid by the purchaser). RMA Number must be clearly marked on the outside of the package(s).

Within a reasonable time after such notification, Mustang will correct any defect(s) in component(s). If Mustang is unable to repair the component after a reasonable number of attempts, or if Mustang determines at any time the repair is impracticable, Mustang will provide a replacement with like or similar component(s). The purchaser is responsible for all transportation expenses to and from Mustang and all labor expenses associated with removal and replacement of the component(s) as well as labor involved to repair component(s). Mustang will bear the expense of parts only. These remedies are the Purchaser's sole remedies for breach of warranty.

The expiration of the warranty period, use of the product for purposes other than those for which it is designed, other abuse or misuse, unauthorized attachments, modifications, or disassembly, or mishandling of the product during shipping, shall end all liability of Mustang.

In no case shall Mustang be liable for any special, incidental, or consequential damages based upon breach of warranty, breach of contract, negligence, strict tort, or any other legal theory. Such damages include but not limited to, loss of profits, loss of savings or revenue, loss of use of product or any associated equipment, cost of capital, cost of any substitute equipment, facilities or services, downtime, the claims of third parties including customers, and injury to property.

Unless modified in writing and signed by officers of both parties, this agreement is understood to be the complete and exclusive agreement between the parties, superseding all prior agreements, oral or written and all other communications between the parties relating to the subject matter of the agreement.

GANCORP INVESTMENTS INC. dba MUSTANG DYNAMOMETER



TABLE OF CONTENTS:

SECTION 1 – INTRODUCTION	7
1.1 WHAT IS A CHASSIS DYNAMOMETER	7
1.2 ABOUT THIS MANUAL.....	8
1.3 IMPORTANT MESSAGE BOXES	9
1.4 BEFORE YOU START.....	10
1.5 IF YOU NEED HELP	10
SECTION 2 – THE SYSTEM	11
2.1 INTRODUCTION	11
2.2 MAJOR SYSTEM COMPONENTS	11
2.2.1 Dynamometer	12
2.2.2a Control and Monitoring System.....	13
2.2.2b Control and Monitoring System (not attached to Dyne).....	14
2.2.3 Software System.....	14
2.3 PRINCIPLES OF OPERATION	14
SECTION 3 – SAFETY FIRST.....	15
3.1 INTRODUCTION	15
3.2 GENERAL SAFETY ISSUES	16
3.3 OPERATIONAL SAFETY ISSUES	17
3.4 MAINTENANCE SAFETY ISSUES	18
SECTION 4 – INSTALLATION.....	19
4.1 INTRODUCTION	19
4.2 INSPECTION	19
4.3 TOOLS AND EQUIPMENT NEEDED FOR INSTALLATION	19
4.4 SHOP LAYOUT AND REQUIREMENTS.....	19
4.4.1 Pit Excavation (Belowground Installation Only)	19
4.4.2 Electrical	20
4.4.3 Pneumatic (air).....	20
4.4.4 Ventilation	20
4.4.5 Floor Anchors.....	20
4.4.6 Clearance	20
4.5 ABOVE GROUND INSTALLATION	21
4.5.1 Above Ground Installation Procedure.....	21
4.6 BELOW GROUND INSTALLATION	27
4.6.1 Below-Ground Installation Procedure	27
INSTALLATION ILLUSTRATIONS:.....	29
4.7 CONTROL INSTALLATION	29
4.8 PRE-OPERATIONAL INSPECTION.....	32
SECTION 5 – OPERATIONAL CHECKOUT	33
5.1 INTRODUCTION	33
5.2 INITIAL START	33
SECTION 6 – PREVENTATIVE MAINTENANCE.....	36
6.1 INTRODUCTION	36
6.2 GENERAL INFORMATION & MAINTENANCE INSPECTION/PROCEDURES	36
6.2.1 Pillow Block Bearings	36
6.2.2 Gear Toothed Couplings	37
6.2.3 Pneumatic Clutch Couplings	38
6.2.4 P.A.U (Eddy Currents).....	39
PREVENTATIVE MAINTENANCE TIME TABLE.....	41



SECTION 7 – TROUBLESHOOTING **42**

7.1 INTRODUCTION 42

7.2 TROUBLESHOOTING GUIDE 42

SECTION 8 – APPENDIX **45**

APPENDIX A – TORQUE SPECIFICATIONS..... 45

APPENDIX B – RECOMMENDED FLUIDS 48

APPENDIX C – ANCHOR POD INSTALLATION- NEW FLOORS 49



SECTION 1 – INTRODUCTION

1.1 WHAT IS A CHASSIS DYNAMOMETER

Today and in the future, automobiles and trucks will be required to meet increasingly stringent emission and safety standards. In many cases, dynamic testing – either on-highway or with a chassis dynamometer is the only way to adequately measure vehicle performance or emissions.

As Mustang Chassis Dynamometer (sometimes referred to as a “dyne” or “dyno”) is a rugged piece of equipment which is used to apply a load to a test vehicle. The Mustang Chassis Dyne is an integrated assembly of mechanical, electromechanical, and electrical/electronic sub-systems which function together to provide you with the ability to simulate actual road loads while the vehicle is being tested remains in the safe and controlled confines of a test center. In addition during a test, this capability will also enable you to connect test instruments and diagnostic equipment to the test vehicle’s engine to monitor specific engine performance characteristics.

As the torque from the test vehicle’s drive wheels cause the rolls of the Dyne to rotate, Mustang’s air-cooled electrical eddy current Power Absorbing Unit (PAU) opposes this force by converting the vehicle’s kinetic energy into heat. A microcomputer-based control unit, using closed-loop feedback control, regulates the amount of power that is absorbed by the PAU and, as a result, the amount of load that is imposed on the test vehicle.

The Chassis Dynamometer has emerged as a major asset in the areas of Emissions Testing, Fault Diagnosis, Performance Engineering, and Test Engineering throughout the world. Chassis Dynamometer can be used to perform a wide variety of test on vehicles; some examples of these tests deal with...

- Vehicle Heating & Cooling Systems
- Engine Performance and Evaluation
- Drive Train Component Evaluation
- Transmission Components
- Tire Testing
- Track Lap Simulation
- Road Grade Simulation
- Trailer Towing Simulation
- Fuel Efficiency
- Auxiliary Components
- Failure Analysis



1.2 ABOUT THIS MANUAL

This manual provides you with the information you will need to know when you want to install and perform routine maintenance as well as more complex service on your MD-AWD-150-Series Chassis Dynamometer. The following sections are included in this manual:

Section 1 – Introduction

This is the section you are currently reading.

Section 2 – The Systems

This section presents a description of the MD-AWD-150-Series Chassis Dynamometer System to familiarize you with its major components. In addition, the principles of dynamometer operation are discussed.

Section 3 – Safety First

A number of very important safety tips are presented in this section. ***Be sure to study this section carefully!***

Section 4 – Installation

A step-by-step procedure is given in this section to help ensure that your dyne is installed properly.

Section 5 – Operational Checkout

A sequence of operational checks is provided in this section to verify that your system is operating properly.

Section 6 – Preventative Maintenance

General maintenance and lubrication instructions are presented in this section.

Section 7 – Troubleshooting

Some basic troubleshooting hints are contained in this section.

Section 8 – Appendices

The appendices contain reference information that you can easily access when you need it.

1.3 IMPORTANT MESSAGE BOXES

When you read this manual, and operate/maintain your Mustang Dynamometer System, **BE SURE TO OBSERVE ALL DANGER, WARNING AND CAUTION ADVISORIES!**

These advisories point out potentially hazardous procedures and conditions. As can be seen below, all three types of advisories are enclosed in a box to call attention to them.

	DANGER
	This is an example of a DANGER message. A DANGER message alerts a person that severe bodily injury or loss of life could occur if procedures are not followed.

	DANGER
	This is an example of an electrical DANGER message. An electrical DANGER message alerts a person that, as a result of electrical shock, severe bodily injury or loss of life could occur if procedures are not followed.

	WARNING
	This is an example of a WARNING message. A WARNING message alerts a person to potential bodily injury if procedures are not followed.

	CAUTION
	This is an example of a CAUTION message. A CAUTION message alerts a person that if procedures are not followed, damage to, or destruction of the equipment could result.

	NOTE
	This is an example of a NOTE box. A NOTE box is generally used to bring to your attention information that should be of particular benefit, information that pertains to a special situation, etc.

1.4 BEFORE YOU START

Before attempting to operate your Dynamometer for normal usage, it is very important that...

- Your Dynamometer has been properly installed.
- Your Dynamometer has been properly maintained.
- Your Dynamometer has been properly calibrated. Please refer to the MD- PowerDyne software manual.
- All personnel who will be performing maintenance and service on your Dynamometer have read this manual in its entirety and understand all of the information presented.

1.5 IF YOU NEED HELP

Much effort has been extended to make this manual easy to work with as well as complete and accurate. However, if there is something that you do not understand or something that you have a question about, please feel free to contact a Mustang Representative at...





SECTION 2 – THE SYSTEM

2.1 INTRODUCTION

This section of the manual provides general information that will help you to develop a comprehensive understanding of your new MD- AWD-150-Series Dynamometer System. The following topics are covered in this section:

- Major System Components
- Principles of Operation

When learning to operate and/or maintain your new Dynamometer we strongly suggest that you take a few moments to familiarize yourself with the information presented in this section of the manual. Doing so will greatly help you to understand the information that is presented in other sections of this manual.

2.2 MAJOR SYSTEM COMPONENTS

The Major components of a MD- AWD-150-Series Dynamometer System can be grouped into the following categories, which are discussed below:

- Dynamometer
- Control and Monitoring System
- Software System

2.2.1 Dynamometer

The Dynamometer sub-system is defined here as being comprised of primarily those system components that are “mechanical” or “structural” in nature. These components are illustrated and discussed below.

Fig. 2.1

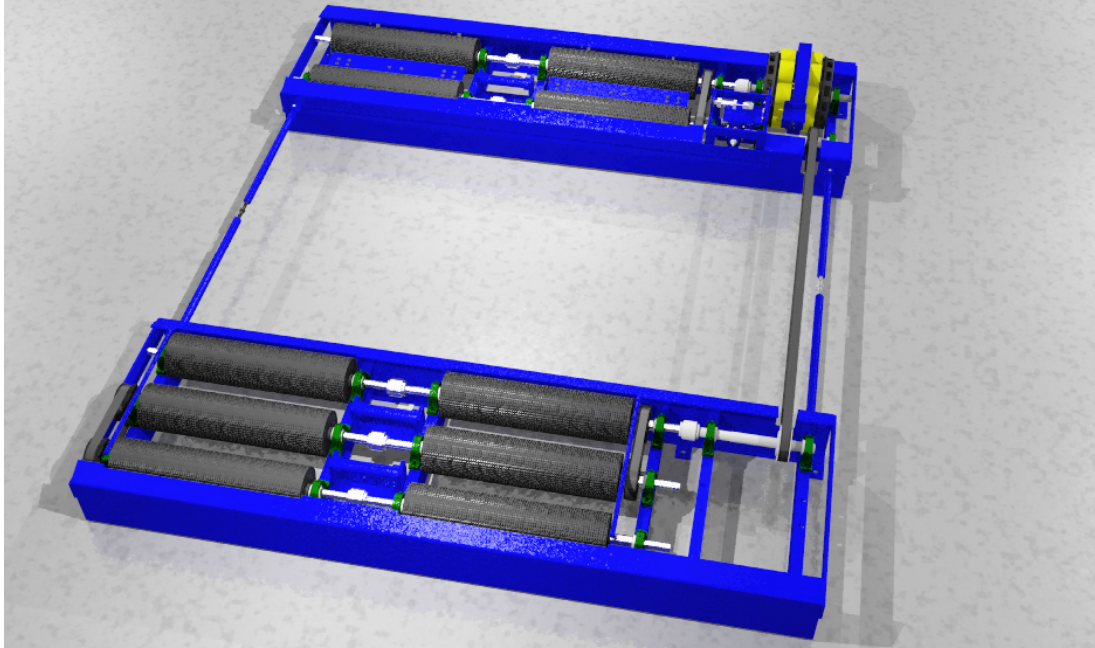

Key (fig. 2.1)

- | | |
|--------------------------|---|
| 1. Frame | Double welded heavy structural steel frame. |
| 2. Pillow Block Bearings | Ball bearings are mounted in a green cast iron pillow block housing for exceptional strength. Bearings can float to minimize misalignment of shafts. |
| 3. Rolls | The dyne is equipped with a Drive Roll set and an Idler Roll set. All rolls are dynamically balanced for speeds up to 150 MPH. The surfaces of the rolls are grooved to provide maximum traction and good tracking. |
| 4. Coupling | High power couplings are used to accurately transmit speed and power to instrumentation. |
| 5. Pneumatic Clutch | High power coupling that is used to disengage the AWD half of the dynamometer so you can test 2 wheel drive vehicles and Motorcycles. |

2.2.2a Control and Monitoring System

The Control and Monitoring Sub-system is defined here as being comprised of those electrical, electro-mechanical, and electronic system components that are primarily used to control the operation of the system and to monitor the behavior of the vehicle during a test. Only those Control and Monitoring Sub-system components that are mounted on the dynamometer are considered in this section; these components are illustrated and discussed below. (See fig. 2.2)

Fig. 2.2

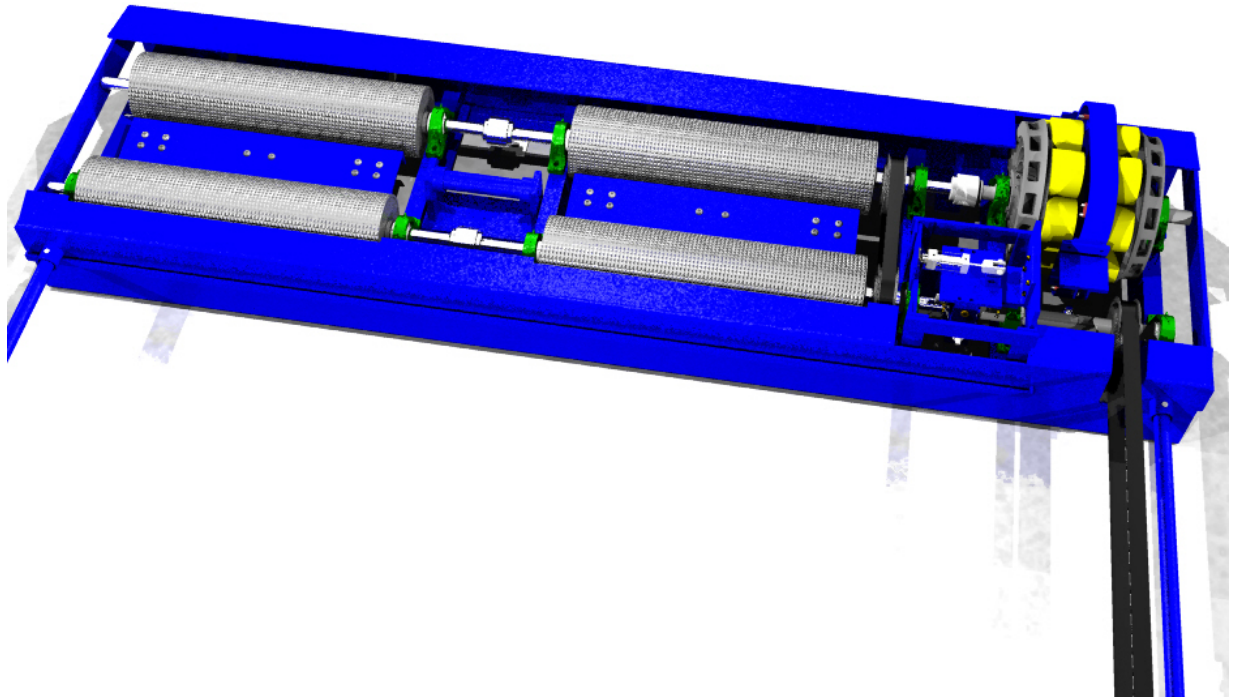

Key (Fig 2.2)

- | | |
|------------------------------|--|
| 1. Power Absorber Unit (PAU) | Eddy current Power Absorbing Units (P.A.U.'s) provide infinitely variable loading without the use of water or hydraulics. The PAU can operate while rotating in either direction. Its rugged construction enables it to be operated under extremely demanding conditions. The PAU is wired for 96 VDC operation. |
| 2. PAU Load Cell | The strain gauge load cell, excited with 10 VDC, produces a DC output signal as it is either compressed or expanded. The rated accuracy of the Load Cell is $\pm 0.1\%$ |
| 3. Magnetic Pick-up | One revolution of the drive line will cause 60 pulses to be generated. By measuring the time between pulses generated, the speed of the rotation can be calculated. |



2.2.2b Control and Monitoring System (not attached to Dyne)

This section will define the Control and Monitoring Sub-system that are not attached to the dyne.

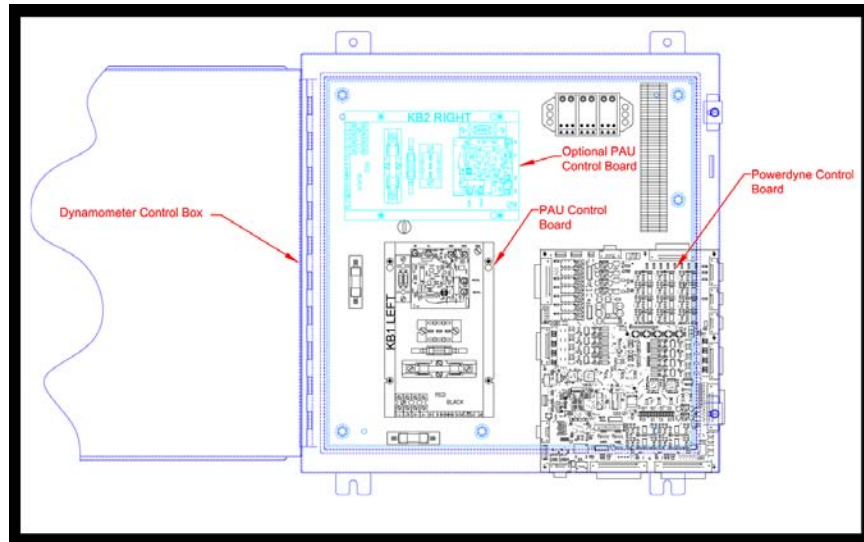

2.2.3 Software System

PowerDyne PC software (the complete PowerDyne PC manual can be found on the software back-up CD.)



2.3 PRINCIPLES OF OPERATION

A Mustang Chassis Dynamometer will give you the ability to simulate actual road loads while the vehicle is stationary. This enables you to perform tests on a vehicle while test diagnostic instruments are connected to the vehicle's engine and exhaust system.

The Dynamometer consists primarily of drive roll sets, power absorbing units (PAUs). The PAUs are belted directly in the dyne's driveline. It is prevented from "freely" rotating by the installation of the load cell. The "load" is measured by the load cell and is transmitted to the control system via an electrical signal. The PAU absorbs this load by energizing stationary electric field coils with a direct current. These coils establish magnetic fields through which the iron rotors of the PAU are rotated. This rotation generates eddy-currents in the rotors, which produce a force that is counter to the direction of the rotary motion. The power absorbed by the PAU is dependent upon the amount of DC power applied to the field coils and the RPM of the spinning rotors. The speed of rotation of the rotors is measured by a magnetic device called a magnetic pickup and is transmitted to the control system.

When both torque (from the load cell signal) and speed (from the magnetic pickup signal) are known, horsepower can easily be determined.

SECTION 3 – SAFETY FIRST



3.1 INTRODUCTION

	DANGER
	Dynamometer operation is potentially dangerous. For your own safety, read and understand the following warnings before conducting any tests. If you cannot read English, or have difficulty understanding these warnings, please ask a supervisor or co-worker to explain them to you.

	DANGER
	This equipment contains voltages, which may be hazardous if contacted. Avoid contacting terminals, binding posts, and other exposed connections.

Throughout this manual you will encounter **DANGER**, **WARNING**, and **CAUTION** messages. These messages are intended to alert you to situations that are potentially dangerous to you or damaging to your machine. Please pay attention to these advisories and follow the directions given in them.

The safety messages presented below are categorized as follows:

-  General Safety Issues
-  Operational Safety Issues
-  Maintenance Safety Issues

The *GENERAL SAFETY ISSUES* apply whenever you are working with the dyne for any reason.

The *OPERATIONAL SAFETY ISSUES* alert you to hazards that may arise during the operation of the dynamometer whether it is being operated for vehicle testing or during an operational checkout.

The *MAINTENANCE SAFETY ISSUES* alert you to hazards that may arise when you are performing maintenance and service on you dynamometer system.

Please be sure to read and follow the directives in all of the safety messages given in this section.



3.2 GENERAL SAFETY ISSUES

BE KNOWLEDGEABLE – Do not attempt to operate, maintain or service your Chassis Dynamometer System until you have familiarized yourself with the equipment by reading the instructions in this manual.

PREPARE CORRECTLY – To avoid possible injury to personnel or damage to equipment do not apply power to your Dynamometer System until the following procedures have been satisfactorily completed;

- Installation (section 4)
- Operational Checkout (section 5)

ACT RESPONSIBLY – Exercise caution and discretion when operating or performing maintenance on your dyne. Always observe typical, common sense test area precautions.

BEWARE OF PROJECTILES – Tires that are rotating at high rates of speed can throw off stones and other projectiles. Wear approved safety glasses when in the vicinity of the vehicle being tested.

PROTECT YOUR EARS – Dynamometer noise can damage your hearing. Always wear approved ear protection when working near the Dynamometer.

BEWARE OF BEING GRABBED – Keep limbs, hair, jewelry, and clothing away from the moving dynamometer rolls, belts, couplings, etc.

COVER ROLLS – The rolls can move freely whenever the roll brake is not applied. Never walk on the rolls. Cover the rolls when the dynamometer is not in use.

PAY ATTENTION – Maintain acute awareness when the dynamometer rolls are in motion.



3.3 OPERATIONAL SAFETY ISSUES

VENT ENGINE EXHAUST – Provide adequate room ventilation. High concentrations of engine exhaust can be deadly. Do not operate your dynamometer without proper ventilation. The shop ventilation system should exchange 300 to 500 cubic feet of air per minute (500 cfm preferred).

MONITOR CARBON MONOXIDE – Make sure you have installed a carbon monoxide monitor in the dynamometer bay.

GUARDING – Provide floor markings and protective guard railings for customer/operator protection. NEVER operate your dyne with any of its cover panels removed unless specifically directed to do so elsewhere in this manual.

REFRESH YOUR KNOWLEDGE – Regularly review the operating procedures presented in this manual.

KEEP CLEAR OF ROLLS – Stay away from the rolls when in operation.

Protect Eyes and Ears – Make sure that you wear proper eye and ear protection when operating the dyne.

CHECK TIRES – Before driving the test vehicle onto the dyne, be sure to check the vehicle's tires for proper inflation. Inspect the tires for any signs of damage and remove any large embedded objects from the tread.

RESTRAIN VEHICLE MOVEMENT – During dynamometer operation it is common for the test vehicle to move laterally on the rolls. Also, unrestrained vehicles can launch off the dyne, causing death or serious injury.

To prevent personal injury and/or damage to the test vehicle, it is imperative that prior to testing the vehicle, you secure the test vehicle in all directions (front, rear, and sides) with approved safety restraints that are bound to properly installed floor anchor pods.

WHEEL CHOCKS – use wheel chocks for your 2WD test vehicles. Install one inch in front of non-driven wheels of test vehicle.

PROPER CLEARANCE – Always ensure that there is a clearance of at least four (4) feet to the front, rear, and sides of the dynamometer.

STAY SEATED – The vehicle operator **MUST** remain in the driver's seat at all times during a drive-cycle test. **DO NOT** attempt to get in or out of the vehicle while the dynamometer rolls are moving.

IF IN DOUBT, STOP! – Stop the equipment immediately if you have any doubt about the safe operating condition of the dynamometer and/or the correctness of any procedure that you are performing.



3.4 MAINTENANCE SAFETY ISSUES

ELECTRICAL SHOCK HAZARD – Turn off electrical service to the system before performing any maintenance activity. Turn off the main breaker in your breaker box before working on anything related to the PAU.

NO JEWELRY – Before performing any electrical or mechanical trouble-shooting, repair, etc. on the dyne, it is highly advisable to remove any jewelry that you may be wearing.

DYNE COVER PANELS – use extreme caution around drive mechanisms and moving parts when operating the dyne with any of its cover panels removed from the chassis assembly.

AVOID STRAINING YOURSELF – Be careful when lifting dyne cover panels – they are very heavy. Be very careful when replacing belts, couplings, or bearings – the rolls are very heavy and can be difficult to handle.

AIR PRESSURE – Make sure that there is no air pressure in the lines whenever you are working on the roll locks, frame lock or pneumatic on/off couplings.

WATCH YOUR HANDS – Never put your hands between the rolls brakes and the roll when there is air hooked up to the system.

NEVER, NEVER, NEVER! – Never pull on the drive belt in order to spin the rolls.

CHECK TIGHTNESS – Make sure that all bolts on the Dyne are tight and all couplings are properly secured.



SECTION 4 – INSTALLATION

4.1 INTRODUCTION

This section of the manual provides instructions that you should follow when installing your new MD-AWD-150-Series Chassis Dynamometer.

These first few steps apply to both above ground and below ground installations.

4.2 INSPECTION

After unloading the dynamometer from the delivery truck and prior to the departure of the truck driver a visual inspection must be made of the dynamometer. If there is any apparent damage to the shipping crates it must be noted on the bill of lading prior to accepting the delivery of the dynamometer. After uncrating the equipment check the contents of the crates with the enclosed packing list. The following is a list of items that should have been received. Notify Mustang Dynamometer immediately if you find any shortages or damage with this shipment.

4.3 TOOLS AND EQUIPMENT NEEDED FOR INSTALLATION

You will need a complete set of standard hand tools, a hammer drill with 5/8-masonry bit, and a 4-foot bubble level. You will also need a forklift with a capacity of at least 12,000 lbs., a minimum of (2) 18' chains with hooks, and a come-along or hoist. Shim stock for leveling the dyne also may be required.

4.4 SHOP LAYOUT AND REQUIREMENTS

This section includes minimum requirements necessary to install the dynamometer and ensure safe operation. After determining which method of installation is best for you it is necessary to adhere to the following conditions.

4.4.1 Pit Excavation (Belowground Installation Only)

A below ground installation requires a floor opening of a very specific dimension. If you have decided that a belowground installation is best for you and your facility, a detailed blueprint was sent to you prior to the dynamometers arrival. However if you chose to have the dyne and prints sent at the same time it is recommended that you contract the services of a licensed contractor to perform the excavating of the dynamometer pit.

	WARNING
	The installer of the dynamometer accepts full responsibility for adhering to local, state and federal construction codes. The factory will not be held liable for damage or injury caused by improper installation.



4.4.2 Electrical

Your new dynamometer will require the following electrical services to operate. A 115 VAC, single phase, 15 Amp circuit is required for the host computer system located on the roll-around cart.

For the single PAU configuration you will need 230VAC, Single Phase, 40Amps
Two (2) PAU configuration you need 230VAC, Three Phase, 40Amps

Your local electrical codes will determine how these circuits should be wired.

4.4.3 Pneumatic (air)

The Dynamometer requires an air supply line to operate the roll brake systems, the movable base locking system and for the air on/off couplings. The airline should supply at least 100 psi but not more than 120 psi. An air dryer and regulator needs be installed in the main supply line.

4.4.4 Ventilation

Your shop should be equipped with an effective ventilation system to direct tailpipe emissions to the outside air. Exhaust vents should be able to connect to all types of vehicles (front-wheel drive, rear-wheel drive, dual exhaust, etc.)

4.4.5 Floor Anchors

It is common for vehicles to move laterally on the rolls during dynamometer operation. To prevent personal injury and damage to the vehicle it is imperative that the vehicle is secured with chains or straps. The dynamometer (belowground only) is shipped with floor anchor pods that must be permanently installed as illustrated in the Appendix.

4.4.6 Clearance

It is important to have enough room around the dynamometer to allow equipment to be move around the service bay area. At least 18 feet clearance is needed in front of the dynamometer so that the vehicle under test has enough room to pull in the service bay.

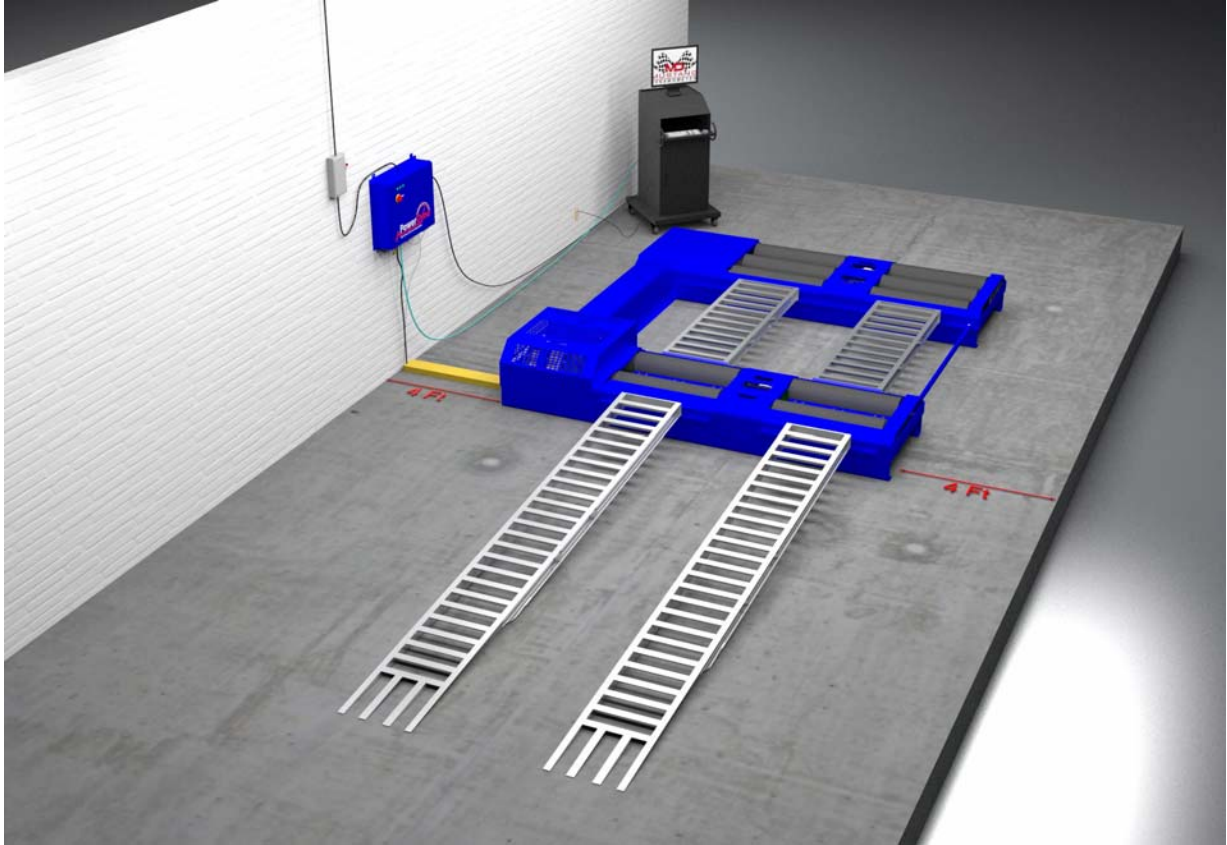

Fig. 4.1

4.5 ABOVE GROUND INSTALLATION

If using this type of installation the dyne and lift will be anchored to the shop floor using “Thunderstuds”. Since the top surface of the dyne will be off the ground, ramps will be needed to drive the test vehicle onto the dyne. There are advantages and disadvantages to both types of installations; the above ground method of installing is less expensive, the shop requires little renovation, the dyne can be moved, however the dyne takes up a large portion of floor space in your shop.

4.5.1 Above Ground Installation Procedure

In this section we’ll go thru step-by-step of the above ground installation. The first few steps apply to both types of installation.

Remove the dyne’s cover plates, do this by using a 5/16 Allen wrench to remove the button head bolts.

Remove the cover or lid above the PAU.

Remove the lag bolts that hold the 4 X 4 wood pieces to the feet of the dyne.



Fig. 4.2a



Fig. 4.2b

Using chains, as shown in Fig. 4.2a and Fig. 4.2b Lift the dynamometer evenly, and then place it in the location of the shop where you wish it to remain. Keep in mind clearance requirements as discussed in 4.4.6, and the fact that there is only 30 feet of cabling shipped with the dynamometer.

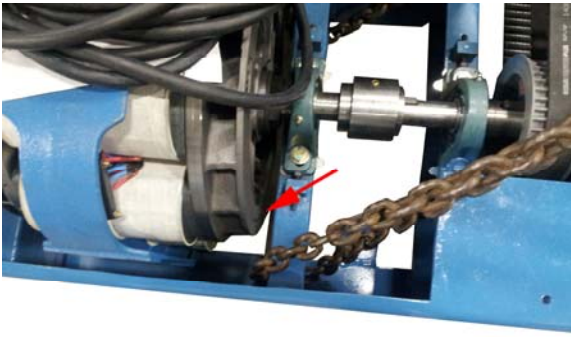

Fig 4.3a



Fig 4.3b

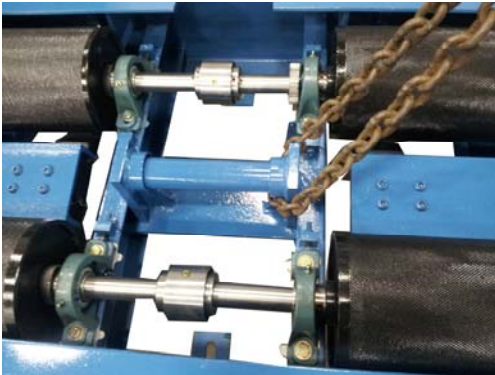

Fig. 4.3c



Fig 4.3d

MAKE SURE THE CHAINS ARE SECURE, if the chains slip when lifting, serious injury can occur. Do not allow the dynamometer to hit the ground. The bearings are very rugged and can easily withstand normal dyne operations, but they will be damaged if there is a sudden impact. (For example dropping the dyne) and when lifting the dynamometer lift slowly and pay attention so that the chain does not slide on the bearing channel and come in contact with the PAU rotor as show by a red arrow in fig 4.3a.... figures 4.3a thru 4.3d show the position of where the chains should be located to safely lift the dynamometer. (All pictures are shown with optional clutch and optional extra roll set and the second PAU. Your dynamometers configuration may differ however the lifting points will remain the same.)

Before placing the dynamometer in your shop, it might be helpful for a reference to “snap” a chalk line on the floor. Using Fig. 4.1 as a reference (ramps facing shop door, and the AWD or larger section of the dyne toward the back of the shop) place the larger section in first... making sure there is a minimum of 4 feet of clearance behind and to the sides of the dynamometer. Then place the spacers (round tubes) on the floor with one end tight up against the AWD section for a guide then place the smaller half in place leaving about an inch gap from the spacers. Then with a come-along pull the dyne halves together while holding the spacers in place.

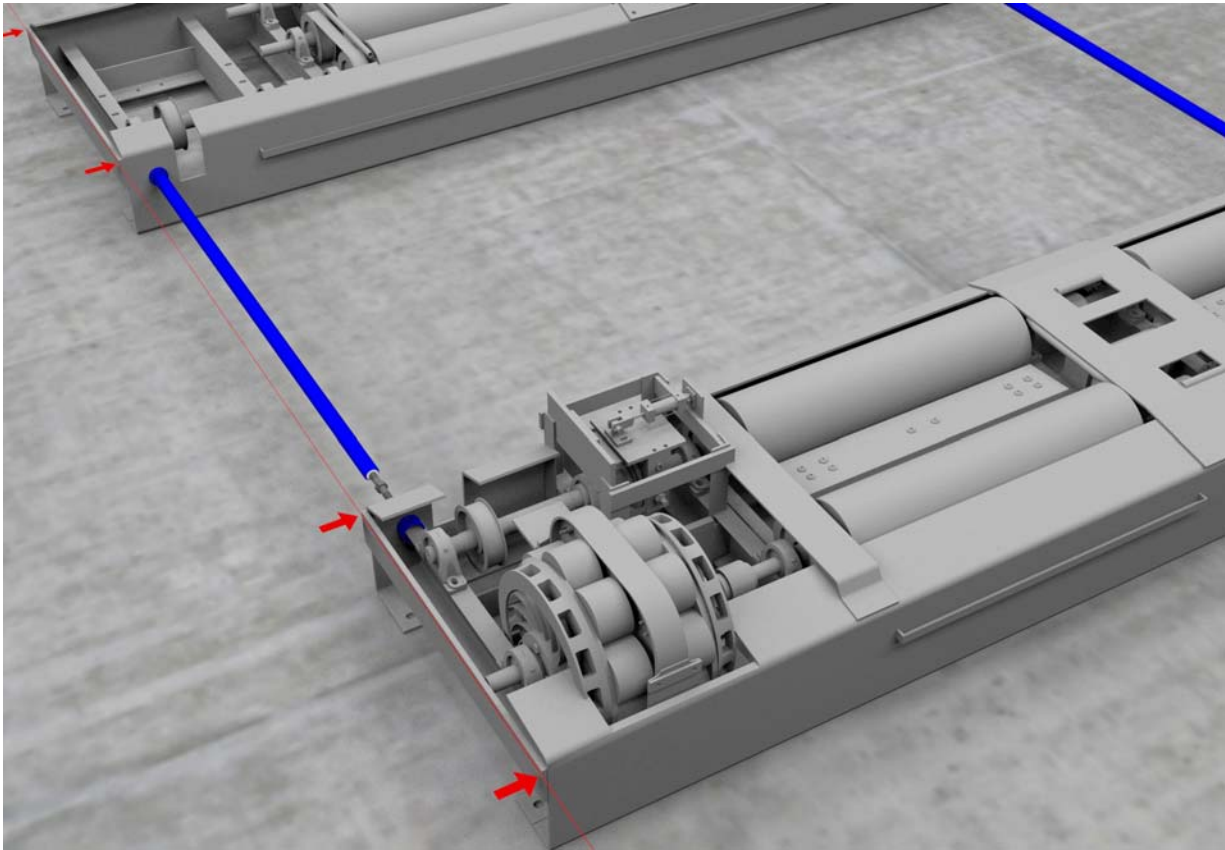

Fig. 4.4

Using the picture above as a reference tape a piece of string to the back corner of the dyne (belt side) then pull to where the string is tight making a perfectly straight line. Then move the dyne halves so that the 4 points indicated by the red arrows just touch the string, using the come-alongs to hold the spacers in place.

Now with the dynamometer in place, and lined up level the dynamometer using steel shim stock. If the dynamometer needs shims, place them underneath the dynamometer frame near the anchor locations.

Using a hammer drill, drill holes and clear all debris from the holes. With the nut of the “Thunderstuds” flush with the top of the stud, tap the “Thunderstuds” into the holes until the nut and washer is flush with the dynamometer’s anchor feet.

Expand the anchors by tightening the nut...

Connect all electrical and air connections.

Next step is to connect the belt, do this by first by removing the coupling sleeve. This is done by locating and removing the snap ring as shown in Fig. 4.5 *note snap ring is not red just highlighted for clarity in the illustration*. Using a small screwdriver or awl remove the snap ring, then slide the sleeve back, a rubber mallet may be needed (Fig. 4.6)

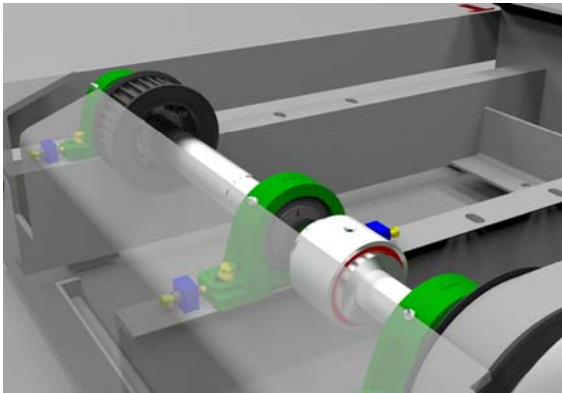

Fig 4.5

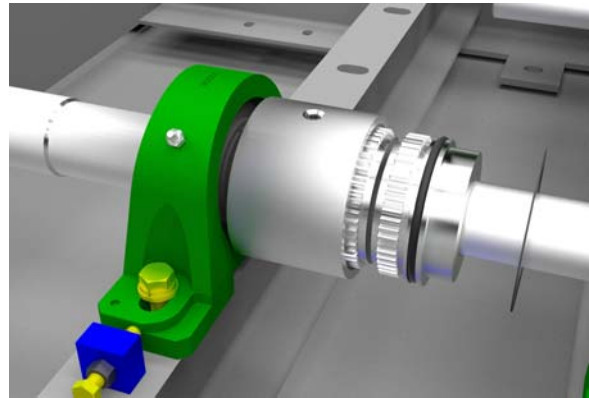



Fig 4.6

Now remove the hardware from the bearings for the sprocket shaft

NOTE	
	When removing the bearings hardware pay attention to any shims that may be under the bearings... these shims need to go back in the exact same position when replacing the sprocket shaft for alignment purposes.

Using figure 4.7 as a guide loosen only two of the bearing adjustment blocks, this will insure proper alignment and belt tension if you only loosen the two indicated with the red arrows.

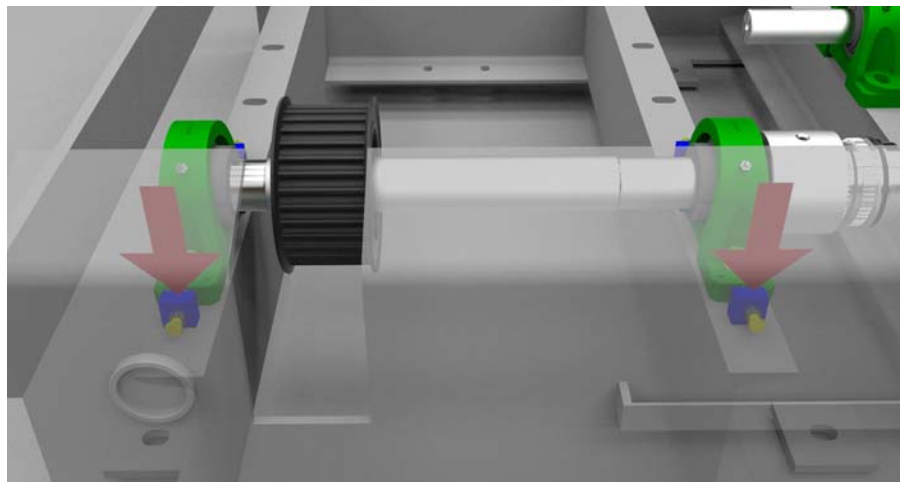

Fig 4.7

Remove the sprocket shaft and place the belt around it... Then replace the sprocket shaft keeping the shims in the same position

Replace bearing hardware and tighten finger tight.

Tighten the bearing block adjustment bolts so that the bearing slides over and makes contact with the opposite side bearing block bolts (the 2 that you didn't move)... tighten the jam nut on the bearing block adjustment bolts.

Tighten bearing hardware and torque to 50 ft-lbs.



Re-connect the sleeve coupling and then replace the snap ring.
Add grease following the steps in the preventive maintenance section of this manual
6.6.

Re-install the dynamometer's plates. Torque the button head bolts to 35 ft. lbs. You will still need access to the PAU for calibration; these steps will be explained in the Power Dyne® software manual, located on the software disc sent with your machine.

4.6 BELOW GROUND INSTALLATION

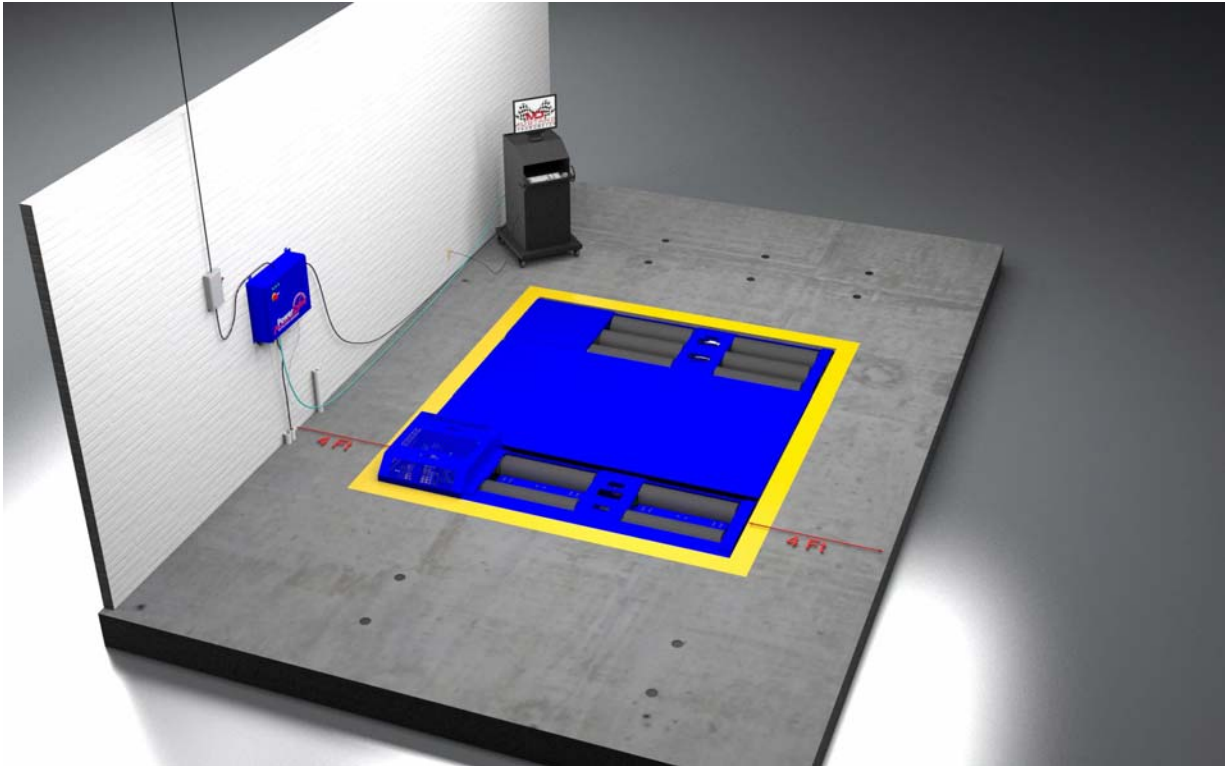

4.6.1 Below-Ground Installation Procedure

In this section we'll go thru step-by-step of the below ground installation. The first few steps apply to both types of installation.

Remove the dyne's cover plates, do this by using a 5/16 Allen wrench to remove the button head bolts.

Remove the dyne's roll cover plates. BE CAREFUL! These plates are very heavy and awkward to balance.

Remove the PAU cover.

Remove the lag bolts that hold the 4 X 4 wood pieces to the feet of the dyne.

Then after the above is completed you need to:

Check dynamometer pit and verify dimensions. Also, make sure the conduits are in the proper locations.

Clear the pit of all debris.

There should be 3 conduits on the bottom of your pit floor, one for the airline, one for the PAU cable and one for the solenoid valve and speed sensor cables. Run these cables now. Make sure that there is enough slack in the cable to make the appropriate



connections. Run a “leader” line for the PAU cable, so that it can be routed after the dynamometer is in place.

Using the chains, as shown in Fig. 4.2 thru Fig 4.3d Lift the dynamometer halves evenly, and place in the pit. There should be approximately 1/2” clearance between the frame and all walls of the pit.

MAKE SURE THE CHAINS ARE SECURE, if the chains slip when lifting, serious injury can occur. Do not allow the dynamometer to hit the ground. The bearings are very rugged and can easily withstand normal dyne operations, but they will be damaged if there is a sudden impact. (For example dropping the dyne) and when lifting the dynamometer lift slowly and pay attention so that the chain does not slide on the bearing channel and come in contact with the PAU rotor as show by a red arrow in fig 4.3a.... figures 4.3a thru 4.3d show the position of where the chains should be located to safely lift the dynamometer. (All pictures are shown with optional clutch and optional extra roll set and the second PAU. Your dynamometers configuration may differ however the lifting points will remain the same.) Carefully place the dynamometer back in the pit. Make sure that the electrical cables are clear of the dynamometer’s anchor feet and will not be crushed.

Before placing the dynamometer in your shop, place the larger section in first.... Then place the spacers (round tubes) on the floor with one end tight up against the AWD section for a guide then place the smaller half in place leaving about an inch gap from the spacers. Then with a come-along pull the dyne halves together while holding the spacers in place.

→Use the same procedures as listed in the above ground installation to align the dyne halves and to connect the belt

Now with the dynamometer in place, level the dynamometer using steel shim stock. If the dynamometer needs shims, place them underneath the dynamometer frame near the anchor locations.

With the nut of the “Thunderstuds” 1/8 inch from the top of the stud, tap the “Thunderstuds” into the holes until the nut and washer is flush with the dynamometer’s anchor feet.

Expand the anchors by tightening the nut.

All the anchor feet may not be accessible, that is why Mustang has placed 4 jacking feet (2 per side) to help secure the dynamometer to the pit. Snug these jacking feet up to the pit wall by tightening the nut located next to the round footpad.

Connect all electrical and air connections.

Re-install the dynamometer’s plates. Torque the button head bolts to 35 ft. lbs. leave the grating above the PAU off. You will still need access to the PAU for calibration; these steps will be explained in the Power Dyne® software manual, located on the software disc sent with your machine.

INSTALLATION ILLUSTRATIONS:

4.7 CONTROL INSTALLATION

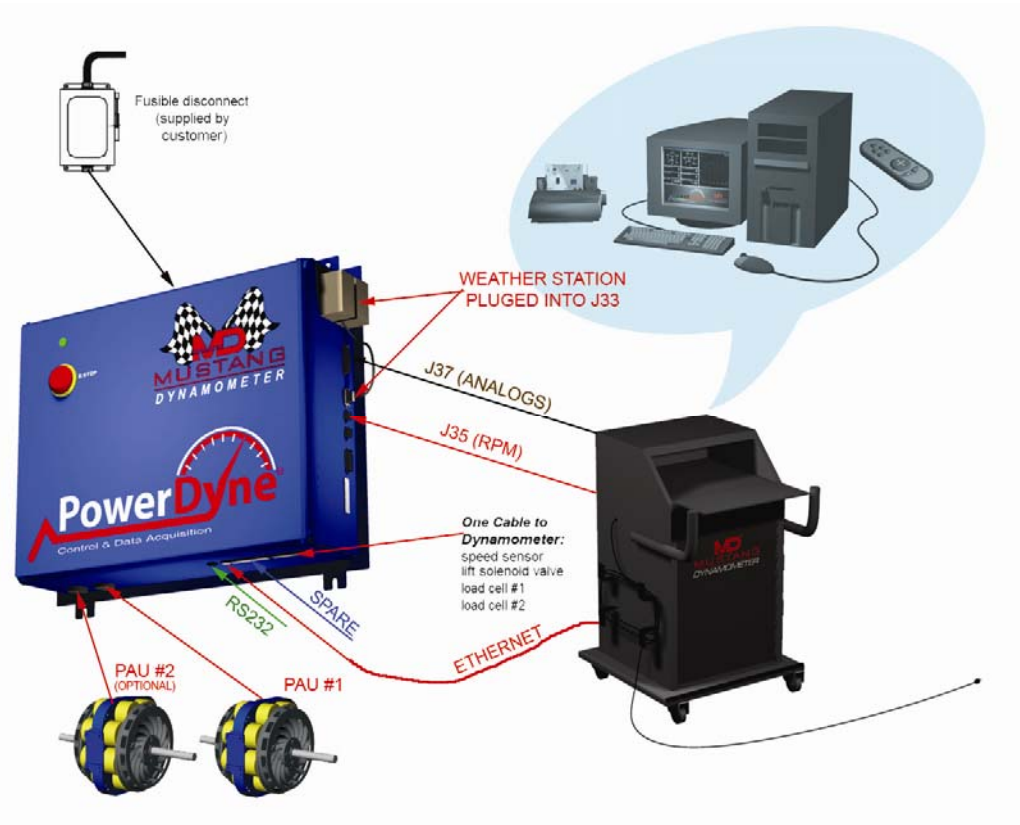

For the control system installation you will need the contents of box # 3 (the box you found this manual in), Monitor, PC, and you will need to install the PowerDyne control box.
NOTE: There is only 30 feet of cable supplied with the dynamometer so double check the placement of the PowerDyne control box to the placement of your dynamometer.



4.7.1 Control System Installation Procedure

1. Take the “dummy” load cell out by removing the large bolts from the upper and lower load cell brackets. Attach the load cell on the lower bracket first. Upon completion, attach the load cell to the upper bracket. Tighten both bolts to 50 ft.-lbs. Torque the eyelet bolt jam nuts to 200 in.-lbs. DO NOT OVER TIGHTEN! NOTE: Position the load cell so the wire is on the side opposite the Power Absorbing Unit.
2. Route cabling and air line. Leave enough slack in the cables and the air line so that the appropriate connections can be made.
3. After routing the air line, push the plastic air line into the quick release air fitting on the air solenoid until it is snug. Make sure that the air line will not come into contact with the rolls.

4. Attach the (2), 3-prong conductor modular plug end of the lift solenoid cable to the brake solenoid using a small screwdriver.



5. Attach the cable with the 3-pin female connector to the speed magnetic pickup.
6. Attach the cable with the 4-pin female connector to the load cell.
7. Connect PAU power cable to the eddy-current power absorber. White wire to the PAU (-), black wire to the PAU (+), and green wire to the chassis ground (refer to figure below).
8. Install main air supply line to the tubing near the conduit run to the dyne. This air supply must have an in line air dryer and must be regulated between 80-120 psi.
9. On the bottom of the PowerDyne® control box there is the lift solenoid. The Red screw (indicated by the arrow in picture to the right) can be pushed in and turned 90° to raise the lifts in case of a power failure so that the test vehicle can be removed from the dyne.



L Make sure there are no personnel near the dyne or lifts before activating the lift override! After test vehicle is removed from the dyne **L** RETURN THIS BYPASS SCREW BACK TO ITS ORIGINAL POSITION!

- 10.

4.8 PRE-OPERATIONAL INSPECTION

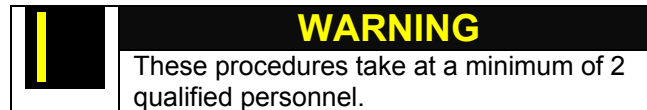

***DO NOT PLUG THE SYSTEM INTO THE POWER SUPPLY.
DO NOT TURN ON THE SYSTEM OR HAVE A VEHICLE ON THE DYNAMOMETER***

1. Verify the installation of the dynamometer meets all guidelines outlined in this manual. Do this NOW by reviewing the step-by-step installation procedures.
2. Verify the proper installation of the chain or strap anchors.
3. Verify and check the torque of all the bolts and set screws to the specifications located in the Appendix. This procedure is very critical as some components may have loosened during shipping.
4. Verify all cable and airline connections are properly fastened, secure, and tightened.
5. Rotate dynamometer rolls by hand or foot (a car should not be on at this time) and verify they spin freely. The rolls will be somewhat difficult to spin due to the large mass that rotates.
6. Check to see that there is plenty of clearance around the rolls and that no components are rubbing, or are near rubbing.
7. Check all cabling and air lines to be sure that they are secured and clearly away from any rotating components.
8. Check the leveling of the dynamometer and ensure it is secured to the floor.
9. Clean up all installation tools in and around the dynamometer frame.



SECTION 5 – OPERATIONAL CHECKOUT

5.1 INTRODUCTION

After the dynamometer has been installed according to the instructions presented in Section 4 – Installation, you should perform the operational checkout procedure given in this section to verify that the dynamometer is operating properly.

5.2 INITIAL START

1. Be sure the system is installed correctly as described in this manual.
2. Turn system ON with all components properly connected and linked to the computer. The system should boot up to Window's XP®, after windows is completely loaded double click on the "PowerDyne PC" icon.

⚠ WARNING: DO NOT DO ANY ADDITIONAL FUNCTIONS WITH THE COMPUTER, STAY AT THE POWERDYNE MAIN MENU SCREEN.



3. Verify the airlines are routed to the proper locations and that the pressure is set between 100 – 120 psi. The air supply must be regulated and dried. Turn air supply on and check for leaks. **⚠ WARNING: BE SURE THAT ALL EQUIPMENT AND PERSONNEL ARE CLEAR OF THE DYNAMOMETER.**
4. Activate the roll lock by clicking on LIFT then up, at the top of the PowerDyne screen. The rolls should be

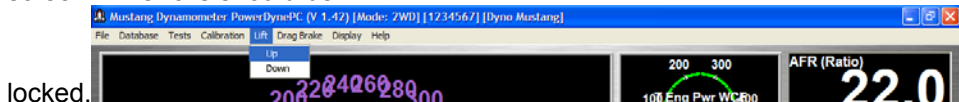

5. Select a "Rear Wheel Drive" vehicle for this initial start-up procedure. Check the vehicles oil level, radiator coolant level, and automatic transmission fluid level (if applicable).
6. Ensure the vehicle tires are at their proper road pressure.
7. Be sure that there is no reason that the vehicle should not be operated on the dynamometer. If, for any reason, there are any doubts, **DO NOT RUN THE DYNAMOMETER**. Instead, please call a Mustang Dynamometer service engineer immediately.
8. Drive the vehicle onto the dynamometer. Be sure the vehicle is squared and centered on the rolls. If the vehicle is not squared and centered, drive off the dynamometer and repeat until the vehicle is squared and centered. Place the vehicle in "Park" or "N" with parking brake, then turn the vehicle's engine off.
9. For the multi roll style dynamometer like the MD-AWD-150 you will need to place **WHEEL CHOCKS** in front of the **NON-DRIVE** wheels only if testing a rear wheel drive vehicle with the front wheels still on the ramp.



10. Release the rolls by clicking lift then down on the top of the PowerDyne computer

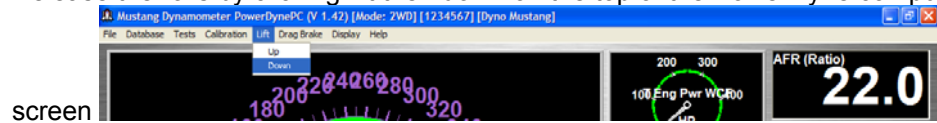

11. Start the vehicle, APPLY THE VEHICLE BRAKE, and put into forward gear. SLOWLY release brake, or clutch, and rotate the tires very slowly (no not exceed 2 MPH). After vehicle has “settled” apply brake, put vehicle into park, and turn engine off and raise the dyne lift. This procedure should only take 10 – 15 seconds.
12. Make sure the tires are clear of the dynamometer’s frame
13. After the vehicle is positioned properly it is **MANDATORY** to secure the vehicle with straps.
14. Connect exhaust removal system.
15. Position the wheel chocks **IN FRONT** of the wheels that are not on the dynamometers rolls.(again this step is only necessary if testing a rear wheel drive vehicle when the front wheels are on the ramp system instead of the AWD roll set section).
16. The dynamometer is now ready for its first rotational break-in test.
L WARNING: THE COMPUTER SHOULD STILL BE IN THE MAIN MENU SCREEN.
17. Be sure all personnel and equipment are clear of the rotating dynamometer and that no personnel stand in front or directly behind the test vehicle.
18. Unlock rolls by clicking “lift” then down on the top of the PowerDyne display.
19. Start the engine and apply brake and/or clutch, place the vehicle in drive gear or low gear.
20. Slowly release brake and/or clutch and check to see if the vehicle tires are rotating on the dynamometer. DO NOT EXIT THE VEHICLE, CHECK WITH YOUR ASSISTANT. **L WARNING: DO NOT ACCELERATE VEHICLE: RUN AT IDLE. BE SURE ALL PERSONNEL ARE CLEAR OF VEHICLE.**
21. Run vehicle for 2 – 3 minutes.
22. Listen for noises, feel and look for vibration. Be sure the vehicle does not sway left/right or back/front. Check for anything unusual.
23. Be sure the driver stays in the vehicle and all personnel stay clear of the dynamometer and of the front and rear of vehicle.
24. If there are any problems, stop the procedure immediately.
25. If no problem occurs, accelerate the vehicle in 10 MPH increments up to 50 MPH for 2 – 3 minutes at each increment.
26. Repeat steps 22, 23, 24 as required.

27. After running the vehicle for 2 – 3 minutes at 50 MPH, let off of the accelerator and let the vehicle coast to a stop. **DO NOT USE THE VEHICLE BRAKES TO SLOW THE DYNAMOMETER!** . Then place the test vehicle in park.
28. Activate the roll locks. Be sure all personnel are clear. Rolls should be now locked.
29. Release and remove all straps and move the wheel chocks from the vehicle.
30. Be sure the exhaust ventilation system is clear. Remove the vehicle from dynamometer.
31. Verify and check the torque of all the bolts and set screws to the specifications located in the Appendix.
32. If You Have Any Questions, Please do not hesitate to call our corporate headquarters at (330) 963-5400 or toll free in the continental united states at 888 4MUSTANG
33. This completes the basic start up rotational test of the equipment.



MUSTANG

DYNAMOMETER

MUSTANG DYNAMOMETER CORPORATE HEADQUARTERS

2300 PINNACLE PKWY.

TWINSBURG, OH 44087

WWW.MUSTANGDYNE.COM

SECTION 6 – PREVENTATIVE MAINTENANCE

6.1 INTRODUCTION

Proper maintenance procedures performed on a regular basis are essential to the well being of any machine. By establishing a preventative maintenance program and then adhering to it, you can lower the risk considerably of finding your dynamometer inoperative just when you need it the most.

Throughout this section the term “normal duty” is used. This is defined by an average use of 40 hours per week. If your application is greater than this, please amend the timetable accordingly.

6.2 GENERAL INFORMATION & MAINTENANCE INSPECTION/PROCEDURES

6.2.1 Pillow Block Bearings

The Dynamometer’s rolls and PAU shafts are supported by a combination of expansion and non-expansion types of ball and high capacity double row spherical roller bearings.

(A) Expansion/Non-Expansion Bearings

During the operation of your dynamometer, temperature changes may cause a linear expansion or contraction of the various components in the system. In a two pillow block arrangement (for example on a given roll), at least one non-expansion type of

bearing is used as an anchor bearing to accommodate thrust loads and position peripheral equipment. The other pillow block may be of the expansion type to accommodate any expansion and contraction in the components. The bearings can be identified as follows:

Expansion-type bearings:

These bearings can be identified by a small white metal disk installed under the grease fitting on the bearing’s housing.

Non-expansion-type bearings:

This type of bearing will have either no disk under the fitting or a small blue metal disk under the fitting.

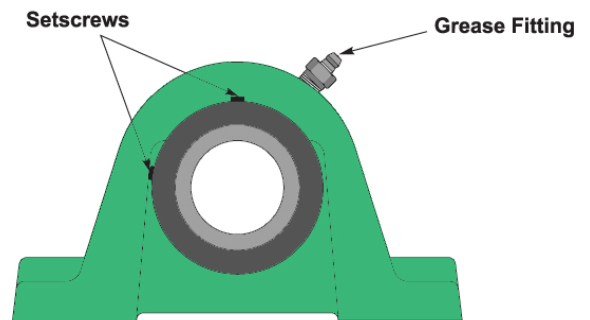



CAUTION

If your dynamometer has not been operated for a long period of time (5 or more months) we **STRONGLY** suggest that you manually rotate the rolls of the dynamometer for about 10 minutes prior to operating the unit. Doing so will enable the bearings to re-establish their self-alignment, thereby minimizing the likelihood of damaging your machine when its is operated under power

(B) Locking Bearing To Shaft

The inner race of each bearing is securely locked to the shaft on which they are mounted by means of two setscrews in the bearing's collar.

For normal duty application, relubricate monthly with Shell Alvania # 2 grease (or standard Lithium base grease # 2), until excess grease is visible at the bearing seals. Wipe off excess grease.

6.2.2 Gear Toothed Couplings

Gear toothed couplings are used in the drive line of your dynamometer between major sub-assemblies (ex. Rolls, PAUs) for the purposes of transmitting torque and enabling the sub-assemblies to be easily removed from the dyne and allowing for slight offset and angular misalignment as well as end float in drive line components.

Once a month remove the grease plugs from the coupling's sleeve on both sides. Using a hand held grease gun, with Shell Alvania # 2 grease (or standard Lithium base grease # 2) pump 2 full pumps into each coupling. Wipe excess grease off with a clean rag and replace grease plugs.



2)

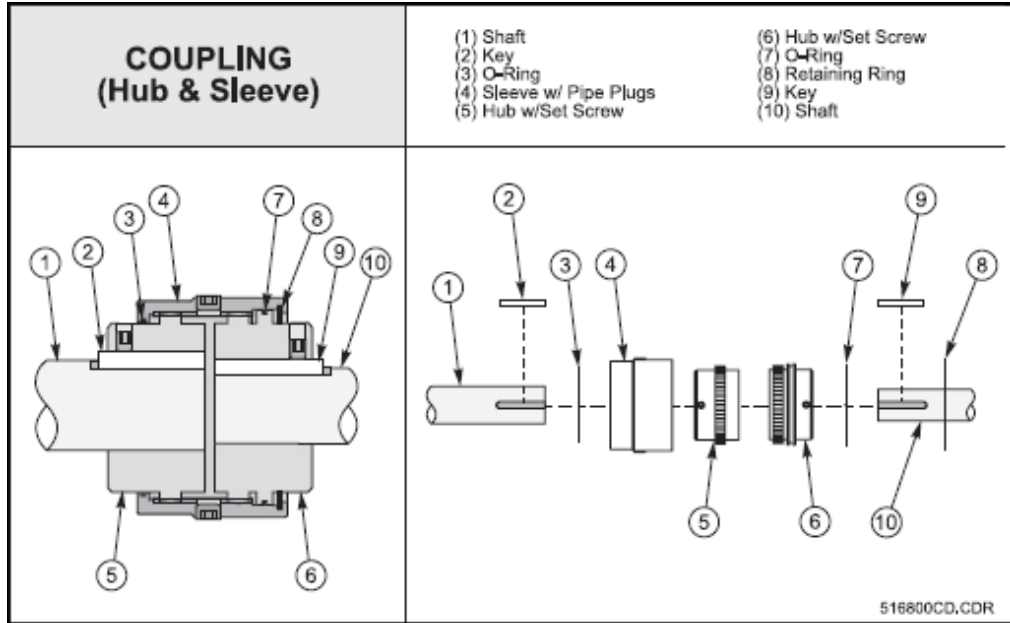

CAUTION

The high centrifugal forces encountered in couplings separate the base oil and the thickener of general purpose greases. Heavy thickener, which has no lubrication qualities, accumulates in the tooth mesh area of gear couplings resulting in premature mesh failure unless periodic lubrication cycles are maintained.

6.2.3 Pneumatic Clutch Couplings

The pneumatic clutch will disengage the long roll so that the dynamometer can test motorcycles. If your dynamometer is equipped with this feature, you will need to grease the cam follower bearings once a week. Using a hand held grease gun pump grease into the zerk (as shown below marked with the red arrow) until the seal “pops” then wipe excess grease from the cam follower.

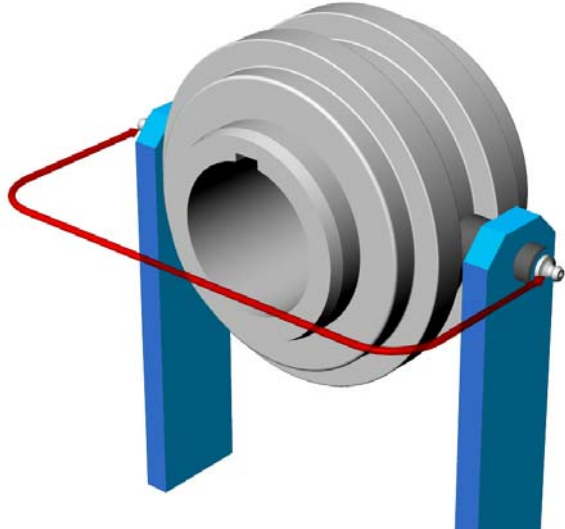

6.2.4 P.A.U (Eddy Currents)

- Eddy current Power Absorbing Units (PAUs) provide infinitely variable loading without the use of water or hydraulics. The PAU can operate while rotating in either direction. Its rugged construction enables it to be operated under extremely demanding conditions. The PAU is wired for 96 VDC operations.
- Lubrication: relubricate monthly using Monolith AW2 grease by inserting grease through the fitting located on the corner of the frame casting, until grease is visible at the weep hole on the frame, at a diagonal location (illustrated below left)

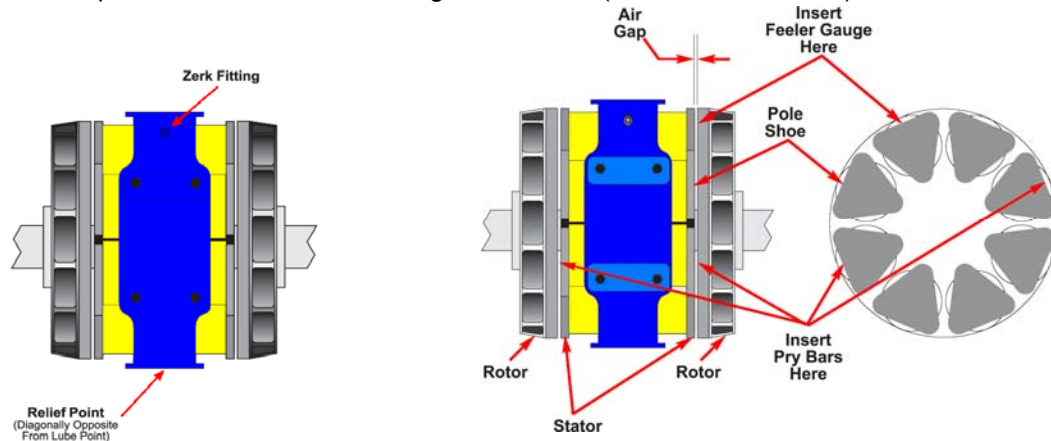

Check Bearing End Play

1. Refer to illustration above (right). Measure the air gap between the rotor and a pole shoe with the rotor forced away from the pole shoe by means of two pry bars (ex. screw drivers) located 180° away from each other and 90° away from the pole shoe being checked. Measure the gap with a feeler gauge.
2. Measure the air gap between the same rotor and the same pole shoe, but with the rotor moved towards the pole shoe by two pry bars (ex. screw drivers) inserted in the air gap on the other side of the power absorber. Do not rotate the rotor when making the above two checks. Place a chalk mark on the pole shoe to prevent accidental rotating of the rotor.
3. The difference between the above two readings is the bearing end play. This value should not exceed 0.005". If the bearing end play exceeds 0.005" contact the factory for adjusting instructions.

Check Rotor Air Gaps

1. Refer to illustration on the previous page. Using feeler gauges, measure and average all eight (8) air gaps on each side of the power absorber. The average air gap measurement per side should be between .053" and .057"
2. If the average air gap is out of range, contact a Mustang Dynamometer Service Representative for adjustment instructions.

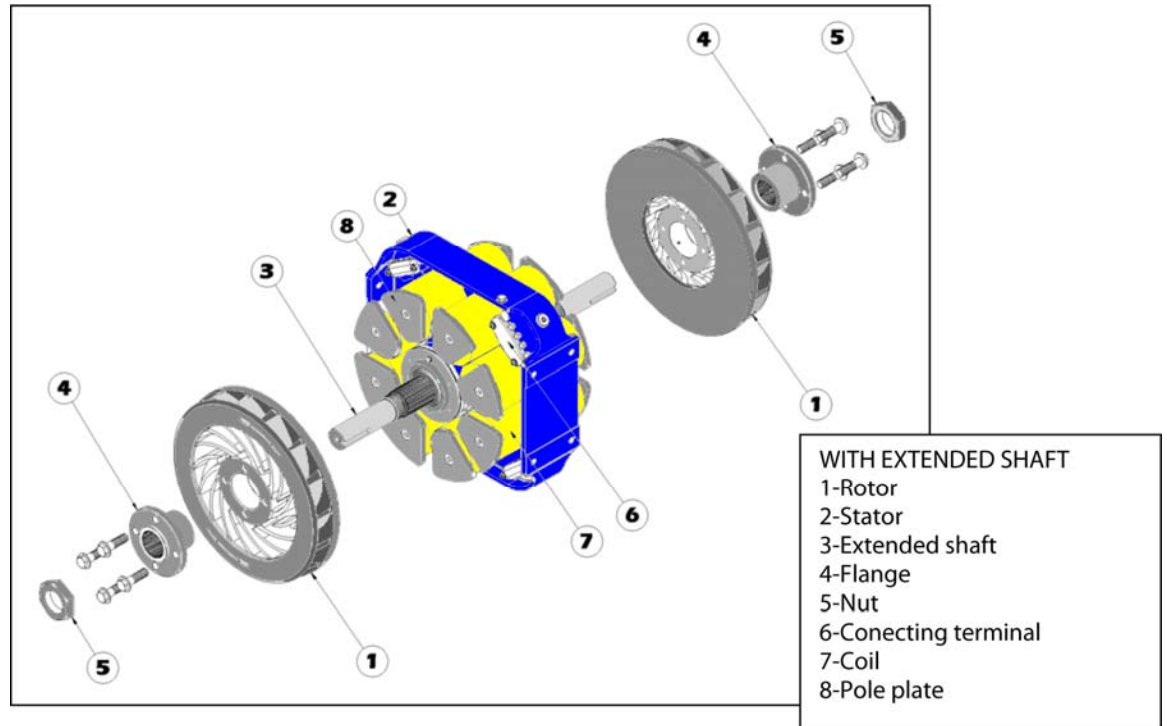



PREVENTATIVE MAINTENANCE TIME TABLE

MAINTENANCE PROCEDURE	BRAKE-IN	WEEKLY	MONTHLY	3 Mo.	6 Mo.	NOTE
LUBRICATION						
COUPLINGS			X			
PAU INTERNAL BEARINGS			X			
PILLOW BLOCK BEARINGS			X			
CAM FOLLOWER BEARINGS		X				
INSPECTION & ADJUSTMENT						
BOLTS – ALL STRUCTURAL			X			
SPEED SENSOR			X			
KEYS – COUPLING			X			
KEYS – SPROCKET			X			
AIR LINES				X		
PAU – BEARING END PLAY					X	
PAU – ROTOR AIR GAPS					X	
SCREW TORQUE – PILLOW BLOCK BEARINGS	•		X			1
SET SCREW TORQUE – COUPLINGS	•	•	X			2
SET SCREW TORQUE – SPROCKETS	•	•	X			2
SET SCREW TORQUE – PILLOW BLOCK BEARINGS	•	•	X			2
CLEANING / CORROSION PREVENTION						
UN - PAINTED METAL PARTS			X			

NOTES:

1. AFTER FIRST 8 HOURS OF OPERATION AND THEN MONTHLY THEREAFTER
2. AFTER FIRST 8 HOURS OF OPERATION, THEN AFTER THE FIRST WEEK, THEN MONTHLY THEREAFTER.

* THIS PREVENTATIVE MAINTENANCE TIME TABLE IS BASED UPON AN AVERAGE OF 40 HOURS OF MACHINE USAGE PER WEEK. IF YOUR INSTALLATION DIFFERS FROM THIS, PLEASE MODIFY THE TIME TABLE ACCORDINGLY.

- THIS REPRESENTS A SPECIAL OPERATION; FOR MORE INFORMATION REFER TO THE APPROPRIATE NOTE ABOVE.



SECTION 7 – TROUBLESHOOTING

7.1 INTRODUCTION

This section of the manual presents information and procedures that will be beneficial to you if you encounter a problem with your dynamometer.

The “Troubleshooting Guide” is provided to help you quickly diagnose and correct problems of a general nature that may arise.

If you encounter a problem with your dynamometer, please don’t panic. Quite often “problems” are the result of something very minor such as forgetting to apply air pressure to the dyne or cables are not connected. When you begin troubleshooting, if appropriate to the problem being observed, check the obvious first. If this does not correct the problem for you, then consult the information presented in this section of the manual. If you are still unable to correct the problem and you have exhausted all possibilities, please feel free to contact a Mustang Service Engineer.

7.2 TROUBLESHOOTING GUIDE

Troubleshooting Guide		
Roll Set		
Problem	Possible Cause	Correction
Vibration and/or noise	Structural frame of dyne is not secured to the floor	Check anchor bolts on dyne frame and tighten to proper specifications.
	Dyne is not level to the floor	Level dyne and be sure shims are in place under frame where needed.
	Roll coupling is out of tolerances or alignment.	Repair or re-align according to factory instructions.
	A Coupling may be worn.	Replace coupling according to factory instructions.
	Roll pillow block bearings not secured to frame.	Tighten bolts to proper specifications.
	Bearing failure on rolls	Replace bearings according to factory instructions.
	Roll has spun on bearing and is worn.	Replace bearings according to factory instructions.
Roll is out of balance	Check to see if there is a spot where a roll weight has come off, check roll shaft for wear: normally needs new roll or tighten set screws on bearing.	

Air Lift System		
Problem	Possible Cause	Correction
Lift fails to lower	Platform override switch in "up" position.	Turn Platform override switch to the "down" position
Lift fails to raise	<p>Air supply to dynamometer has not been turned on.</p> <p>Airlift solenoid coil has failed.</p> <p>Airlift solenoid actuated valve has failed.</p> <p>Power supply failing to operate properly.</p> <p>Roll speed other than zero is being displayed.</p> <p>Low air pressure.</p> <p>Defective or improperly wired air pressure switch.</p> <p>Defective cable or connector</p> <p>Digital enable signal from host computer is not present.</p>	<p>Turn on air supply. Dry air, regulated to maximum of 120 psi. must be furnished to the dyne</p> <p>Check for +12 VDC across Pins 8 & 9 in control unit. If necessary replace solenoid coil.</p> <p>Replace valve</p> <p>Check all connections in control unit and solenoid valve cables. If necessary repair or replace defective components.</p> <p>Troubleshoot speed sensor and wiring.</p> <p>Adjust dry, regulated air pressure furnished to dyne to a maximum of 120 psi.</p> <p>Verify correct wiring and test opening and closing of pressure switch contacts.</p> <p>Inspect all electrical wiring and replace any defective cables and/or connectors.</p> <p>Troubleshoot software system. Troubleshoot dyne control unit.</p>
Rolls do not lock	<p>Brake pads are worn</p> <p>Air leak in pneumatic system.</p> <p>Pins at lift points are missing.</p> <p>Low air pressure</p>	<p>Replace brake pads</p> <p>Inspect and replace any defective tubing, connectors, and/or air bags.</p> <p>Replace missing pins</p> <p>Adjust dry, regulated air pressure furnished to dyne to a maximum of 120 psi.</p>



Operational Problems		
Problem	Possible Cause	Correction
Display values not stable (i.e. floating, fluctuating, etc.)	Loose interface connection	Make sure that all cable connectors are properly seated. Verify that all connections inside the junction box are secure.
	Bad load cell connection	Check and, if necessary, repair all load cell connections.
No Speed Readout	Bad electrical connection	Check all electrical connections in the system.
	Incorrect magnetic pickup to gear air gap.	Verify that the air gap is set to 0.020"
	Magnetic pickup failure	Replace magnetic pickup.

SECTION 8 – APPENDIX

APPENDIX A – TORQUE SPECIFICATIONS

TAPERED QD-STYLE BUSHING BOLTS					
TORQUE SPECIFICATIONS		PLAIN BUSHING	TORQUE SPECIFICATIONS		IDLER BUSHING W/BEARINGS
BOLT SIZE		TORQUE	BOLT SIZE		TORQUE
#10-24		60 in.-lbs. 6.8 Nm	1/4-20		60 in.-lbs. 6.8 Nm
1/4-20		110 in.-lbs. 12.4 Nm	5/16-18		95 in.-lbs. 10.7 Nm
5/16-18		180 in.-lbs. 20.3 Nm	3/8-16		15 ft.-lbs. 20.3 Nm
3/8-16		30 ft.-lbs. 40.7 Nm	1/2-13		30 ft.-lbs. 40.7 Nm
1/2-13		60 ft.-lbs. 81.3 Nm			
9/16-12		75 ft.-lbs. 101.6 Nm			
5/8-11		135 ft.-lbs. 182.9 Nm			
3/4-10		225 ft.-lbs. 304.9 Nm			
7/8-9		300 ft.-lbs. 406.5 Nm			
1-8		450 ft.-lbs. 609.8 Nm			

TORQUE SPECIFICATIONS		GENERAL MOUNTING BOLTS		
(STANDARD ANSI B18.2.1-1981, HHCS SAE 5 OR BETTER W/WASHERS)				
(METRIC ANSI B 18-2-2-1-1979, HHCS GRADE 8.8 OR BETTER W/WASHERS)				
BOLT SIZE	TORQUE	BOLT SIZE	TORQUE	SOCKET SIZE
1/4-20	100 in.-lbs. 11.3 Nm	1/4-28	110 in.-lbs. 12.4 Nm	7/16
5/16-18	200 in.-lbs. 22.6 Nm	5/16-24	215 in.-lbs. 24.3 Nm	1/2
3/8-16	30 ft.-lbs. 40.7 Nm	3/8-24	30 ft.-lbs. 40.7 Nm	9/16
7/16-14	45 ft.-lbs. 61 Nm	7/16-20	50 ft.-lbs. 67.8 Nm	5/8
1/2-13	70 ft.-lbs. 94.9 Nm	1/2-20	75 ft.-lbs. 101.6 Nm	3/4
9/16-12	100 ft.-lbs. 135.5 Nm	9/16-18	110 ft.-lbs. 149.1 Nm	13/16
5/8-11	135 ft.-lbs. 182.9 Nm	5/8-18	150 ft.-lbs. 203.3 Nm	15/16
3/4-10	240 ft.-lbs. 352.2 Nm	3/4-16	265 ft.-lbs. 359.1 Nm	1 1/8
7/8-9	390 ft.-lbs. 528.5 Nm	7/8-14	420 ft.-lbs. 569.1 Nm	1 5/16
1-8	585 ft.-lbs. 792.7 Nm	1-12	620 ft.-lbs. 840.1 Nm	1 1/2
M6 1	85 in.-lbs. 9.6 Nm	M6 0.75	95 in.-lbs. 10.7 Nm	10mm
M8 1.25	210 in.-lbs. 23.7 Nm	M8 1	225 in.-lbs. 25.4 Nm	13mm
M10 1.5	35 ft.-lbs. 47.4 Nm	M10 1.25	35 ft.-lbs. 47.4 Nm	16mm
M12 1.75	60 ft.-lbs. 81.3 Nm	M12 1.25	65 ft.-lbs. 88.1 Nm	18mm
M14 2	95 ft.-lbs. 128.7 Nm	M14 1.5	105 ft.-lbs. 142.3 Nm	21mm
M16 2	150 ft.-lbs. 203.3 Nm	M16 1.5	160 ft.-lbs. 216.8 Nm	24mm
M20 2.5	295 ft.-lbs. 399.7 Nm	M20 1.5	325 ft.-lbs. 440.4 Nm	30mm
M24 3	505 ft.-lbs. 684.3 Nm	M24 2	555 ft.-lbs. 752 Nm	36mm



TORQUE SPECIFICATIONS	FLEXIBLE DISC COUPLING BOLTS
<i>BOLT SIZE</i>	<i>TORQUE</i>
1/4-28	155 in.-lbs. 17.5Nm
5/16-24	25 ft.-lbs. 33.9 Nm
3/8-24	30 ft.-lbs. 40.7 Nm
7/16-20	40 ft.-lbs. 54.2 Nm
1/2-20	95 ft.-lbs. 128.7 Nm
9/16-18	130 ft.-lbs. 176.2 Nm
5/8-18	175 ft.-lbs. 237.1 Nm
11/16-16	200 ft.-lbs. 271 Nm
3/4-16	260 ft.-lbs. 352.3 Nm
7/8-14	350 ft.-lbs. 474.3 Nm
1-14	335 ft.-lbs. 453.9 Nm

TORQUE SPECIFICATIONS	BEARING MOUNTING BOLTS
<i>BOLT SIZE</i>	<i>TORQUE</i>
3/8-16	20 ft.-lbs 27.1 Nm
1/2-13	50 ft.-lbs. 67.8 Nm
5/8-11	100 ft.-lbs. 135.5 Nm
3/4-10	175 ft.-lbs. 237.1 Nm
7/8-9	200 ft.-lbs. 271 Nm
M10 1.5	20 ft.-lbs. 27.1 Nm
M12 1.75	35 ft.-lbs. 47.4 Nm
M16 2	90 ft.-lbs. 122 Nm
M20 2.5	175 ft.-lbs. 237.1 Nm
M22 2.5	235 ft.-lbs. 318.4 Nm

TORQUE SPECIFICATIONS	BEARING SET SCREWS (ANSI B 18.3-1986, BS 4168-1981)	
<i>SET SCREW SIZE</i>	<i>TORQUE</i>	<i>HEX KEY SIZE</i>
#10-32	30 in.-lbs. 3.4 Nm	3/32
1/4-28	75 in.-lbs. 8.5 Nm	1/8
5/16-24	140 in.-lbs. 15.8 Nm	5/32
3/8-24	250 in.-lbs 28.2 Nm	3/16
1/2-20	50 ft.-lbs. 67.8 Nm	1/4
5/8-18	110 ft.-lbs 149 Nm	5/16
M5 0.8	30 in.-lbs. 3.4 Nm	2.5mm
M6 1	60 in.-lbs. 6.8 Nm	3mm
M8 1.25	140 in.-lbs. 15.8 Nm	4mm
M10 1.5	250 in.-lbs. 28.2 Nm	5mm
M12 1.75	40 ft.-lbs. 54.2 Nm	6mm

TORQUE SPECIFICATIONS	COVER PLATE BOLTS (ANSI B18.3-1986, BUTTON HEAD CAP SCREWS)	
<i>BOLT SIZE</i>	<i>TORQUE</i>	<i>SOCKET SIZE</i>
3/8-16	15 ft.-lbs. 20.3 Nm	7/32
1/2-13	35 ft.-lbs. 47.4 Nm	5/16
5/8-11	70 ft.-lbs. 94.9 Nm	3/8

TORQUE SPECIFICATIONS	POWER ABSORBER FASTENERS
TYPE	TORQUE
Main Shaft Nut	
K-40 to K-160	325 ft.-lbs. 440 Nm
K-200 to K-480	470 ft.-lbs. 640 Nm
K-70 CHI	470 ft.-lbs. 640 Nm
Flange to Rotor Bolts	
K-40 to K-160	150 ft.-lbs. 205 Nm
K-200 to K-480	200 ft.-lbs. 275 Nm
Flange Bolts	
Size 1410 Flange	85 ft.-lbs. 120 Nm
Size 1600 Flange	50 ft.-lbs. 70 Nm
Pole Plate Bolts	
K-40 to K-160	50 ft.-lbs. 270 Nm
K-200 to K-480	85 ft.-lbs. 120 Nm
Seal Plate Bolts	
	85 in.-lbs. 9 Nm
Terminal Block Nuts	
M5	20 in.-lbs. 1.95 Nm
M6	30 in.-lbs. 3.43 Nm



APPENDIX B – RECOMMENDED FLUIDS

RECOMMENDED FLUIDS			
MD PART NUMBER	MANUFACTURER	DESIGNATION	DESCRIPTION
GREASE			
20010651	Mobil	Mobilith AW2	Used in all general bearings. Multi-purpose, lithium-complex grease; Excellent protection against rust and corrosion, smooth and tacky, green in color
OIL			
20010653	Mobil	SHC 634	Used in all gear boxes.
CORROSION PREVENTION			
20014736	Sprayon	#710 PDRP	Used on all bright metal parts. A heavy duty water displacing film that provides great protection in salt water and high humidity atmosphere; does not contain silicon; will penetrate and lubricate non-accessible areas. Easily removed with petroleum solvents.
ADHESIVE			
20010654	Loctite	Loctite 262	Permanent thread locker.

Appendix C - Anchor Pod Installation - New Floors

The procedure given below should be followed when you want to install anchor pods in a floor that is going to be poured.

NOTE: The frame numbers in the illustration correspond to the procedure steps below.

- [1] Using the butt-end of a sledge hammer, tap on the anchor expander wedge until it breaks loose from the sleeve.
- [2] Place the anchor sleeve on its side on a hard surface. Using a hammer, strike each of the four slotted section ends until the diameter of the sleeve has been reduced enough so the floor plate can slide easily over the sleeve.
- [3] Install the floor plate over the slotted end of the sleeve until it is about 1/3 of the way onto the anchor. When properly positioned, 1/2" to 3/4" of the slot should remain below the floor plate.
- [4] Place the anchor expander wedge back into the sleeve and strike it with a hammer until the anchor expander wedge is secured. When properly installed, about 1/4" of the wedge will be exposed at the bottom of the sleeve.
- [5] Install the chain and the retainer wedge into the base of the anchor expander wedge. Make sure that only one link of the chain extends below the expander wedge.
- [6] Wad up one full size sheet of newspaper for the outside base of the anchor and one for the inside top of the anchor. Tape the wad of newspaper fully onto the base so concrete will not contact the underside of the anchor and seize the chain after it has cured. This measure will ensure that the chain can, if necessary, be removed at a later time.
- [7] Fully tape all slots so concrete will not seep into the anchor during the pouring operation. The wad of newspaper inside the top portion of anchor is added insurance against seepage of concrete into anchor interior. Turn the anchor pod lid (not illustrated) upside down so the logo is facing inwards and then tape the lid securely onto the anchor. The anchor is now ready to be set into place.
- [8] Lay out the desired anchor pod locations. When properly installed, the top of each anchor should be level with the finished concrete. Install a string above each anchor pod to represent the final concrete level. Raise the top of the anchor to the string and begin pouring the concrete. If time allows, it is best to "set" each anchor with a batch of concrete first. When this concrete has hardened, complete the concrete pouring and finishing.

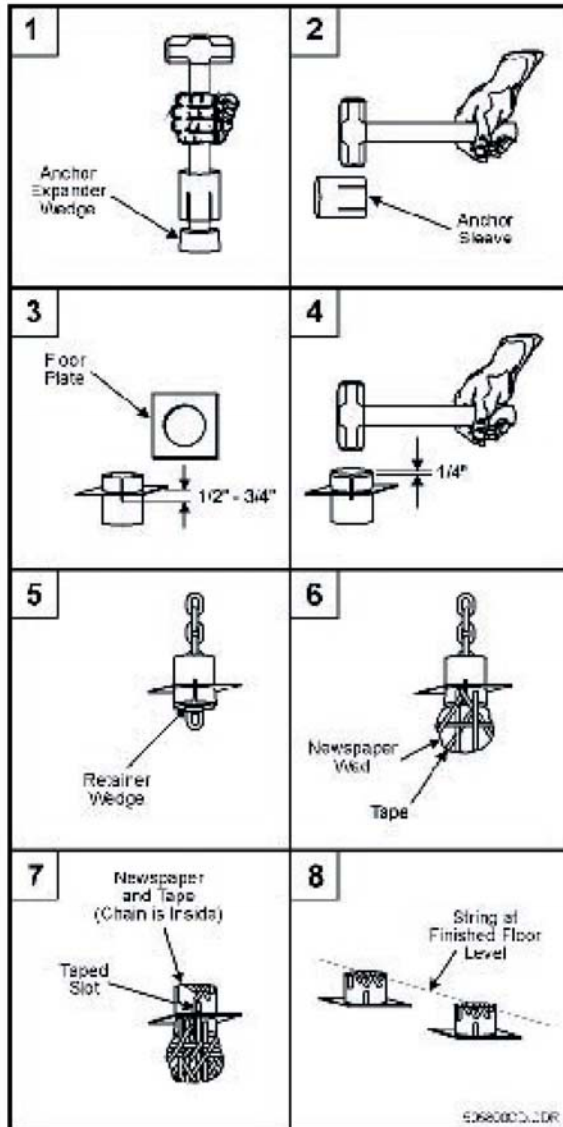

CAUTION: Allow the new concrete floor to cure for 11 weeks before pulling on the anchors. The newspaper wrapped under the anchor will decompose, leaving access for chain removal